

Victorian 'RUFFORD' 19 Wide Assembly Instructions

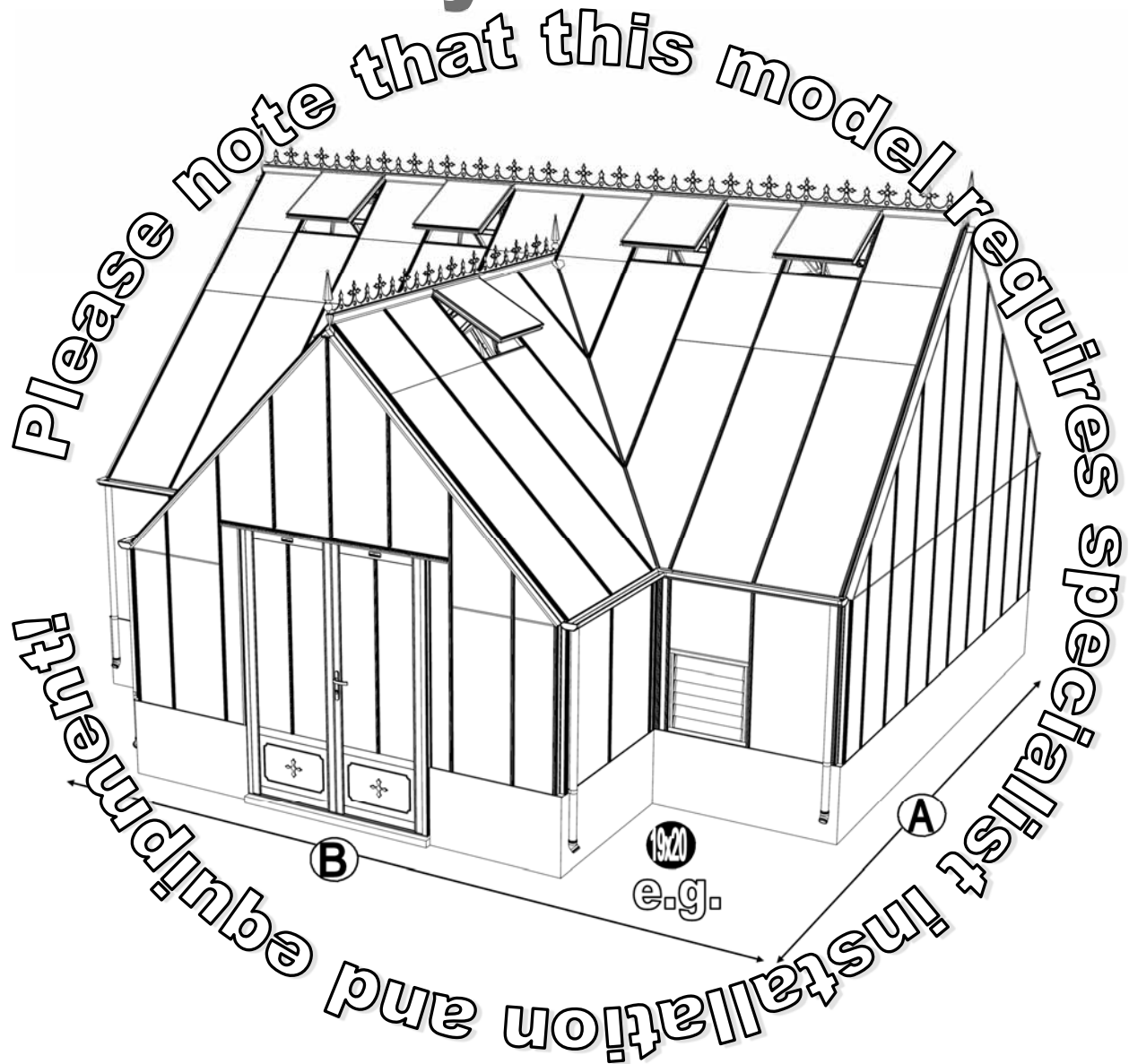

| NOMINAL SIZE | A (mm) | B (mm) |
|--------------|--------|--------|
| 19 x 12 | 5851 | 3826 |
| 19 x 20 | | 6306 |
| 19 x 28 | | 8786 |
| 19 x 36 | | 11266 |
| 19 x 44 | | 13746 |



Thank you for purchasing your new Robinsons greenhouse. We recommend you familiarise yourself with the instructions and read all safety information before you commence assembly. This instruction manual is also available online at www.robinsongreenhouses.co.uk in our technical help section should you need to reprint it. Should you require any additional advice you can always call us on 01782 385409.

These instructions are divided into sections highlighted by a white number/letter on a black background at the bottom corner of most pages (see opposite page for details); **part lists**, **B**-base, **P**-preparation, **1**-rear, **2**-porch gable, **3-14'** wide end gables (**3P**=plain gable, **3D**=optional single door end gable), **4**-porch sides, **5**-main frame assembly, **6a**-main roof, **6b**-porch roof, **7**-vent, **8**-louvre, **9**-glazing, **10**-vent attachment, **11**-door attachment (**11DD**=double porch doors, **11SD**=gable end single door), **12** anchoring down, **13** finishing touches, **14** optional shelf, **15** optional staging. If you need to contact us for assistance please refer to the relevant section/s. If your building is longer than 12' it will have 4' and/or 8' extensions supplied to extend the 12' porch core, e.g. a 28' long model is a 12' core model with an 8' extension either side of it. Reinforcing A-frames are sited at the extension joints, see section 5.

Safety Warning

- Glass and aluminium can potentially cause injury. Please ensure you wear protective goggles, gloves, headgear and suitable footwear when assembling and glazing the building.
- Please remember that glass is fragile and should be handled with extreme care. Always clear up and dispose of any breakages immediately.
- Do not assemble the greenhouse in high winds.
- For safety reasons and ease of assembly, we recommend that this greenhouse is assembled by a minimum of two people.
- Please clear all lying snow from the greenhouse roof as it can cause the roof to buckle or collapse.

Site Preparation

- When selecting a site for your greenhouse, it is vital that you choose as flat and level an area as possible.
- At over 4m tall this model will require some very substantial ladders and possibly some scaffolding to build and glaze the frame.
- A concrete or slabbed base will provide the most solid foundation for your greenhouse.
- IMPORTANT: Do **not** fix your building down until the building is fully assembled, including glazing.
- Avoid placing your greenhouse under trees or in other vulnerable locations.
- To minimise the risk of wind damage, try to select as sheltered a site as possible, e.g. beside a hedgerow or garden fence.

Additional Considerations

- Please bear in mind that assembling your greenhouse can be time consuming. You may need to spread the construction over three or more days. We recommend that you avoid leaving the building partially glazed. If you ever have to leave your greenhouse half assembled and not anchored down, weigh it down with slabs or bags of sand to stop the wind moving it.
- You will find it helpful to prepare a large, clean and clear area in which to work in. A garage floor or flat lawn area is ideal.
- If you have arranged for someone to install your greenhouse for you, please check that all components are included. The components can be identified by their distinctive profiles, lengths and quantities detailed in the parts list (see next page).
- Anchoring down your greenhouse should be the final stage of construction (including glazing).
- Once installed your greenhouse requires little maintenance, but to maintain the smooth running of your doors WD40 or similar can be applied to the door pivot pins / lock etc...

Guarantee

- Your new Robinsons greenhouse is guaranteed for 10 years against faulty manufacture of the frame-work. This does not include glazing, moving parts, accidental damage or wind damage.

| KEY SYMBOL | KEY DESCRIPTION |
|------------|---|
| | EXTERNAL VIEW |
| | INTERNAL VIEW |
| | THINK |
| | THIS SECTION RELATES TO ANOTHER (e.g. 1 to 5) |
| | CORRECT |
| | DO <u>NOT</u> FIX DOWN! |
| | TWIST TO LOCK |
| | TIGHTEN |
| | CUT TO LENGTH |

UPDATE: Robinsons plastic / aluminium cover strips -

On a Robinsons building the glazing capping is in two parts. The lower plastic capping screws into the glazing bars pressing the glass down onto its rubber beading. The upper plastic / aluminium covers then need to be applied to cover the heads of the self-tapping screws. If you are struggling to press on the cover strips then we recommend the use of a rubber mallet or perhaps a wooden block and hammer, a short sharp tap onto the cover at one end is all that is needed to stretch the cover around the lower capping protrusions locking it into place. You can then either continue to use the mallet along the length of the cover or continue just using the palm of your hand. Once in the building and the edges are protected Robinsons 4mm thick toughened safety glass is very strong and can cope with the vibrations caused by hitting the covers though we would not recommend that you hit the glass directly. Some of the aluminium cover caps have a hole in them at one end which is sometimes used to hang the parts for powder coating. You can if you wish use the hole to stop the covers from sliding in the roof using a glazing screw, note you will have to use a countersunk screw under the vents to avoid interference with the vent bottom.



| SECTION No | TITLE | ASSEMBLY SYNOPSIS: IMPORTANT INFORMATION / CONSIDERATIONS |
|------------|-------------------------|---|
| | PARTS LIST | Identify and separate all like for like components prior to assembly. The 'parts list' also separates parts into the various sections 1 - 13 shown below. Parts can also be identified by their profile pictures and stated lengths etc.. |
| B | BASE | Wall dimensions and recommendations. Ensure that your base is level as this will make assembly of the building, especially the glazing of the roof much more straight forward. Please be aware that the hinge doors on your greenhouse opens inwards, make sure that there will be no interference between the doors and the foundations. |
| P | PREPARATION | Tools required. IMPORTANT: Use WD40 or similar in the glazing bar channels and insert the black glazing rubber prior to frame assembly. |
| 1 | REAR | Take the glazing bars 'D609' with the rubber inserted and the diagonal braces 'D604', use 12mm bolts to join them to the gutter and 16mm bolts to the cills (note how the head of the bolt slides into each glazing bar during construction). Please also remember to slide in your 22mm bolts for attaching the decorative eave spandrels 'DV100' in section 6. The diagonal 'D604' braces move to be adjacent to the 14' end gables with 12'+ extended models. |
| 2 / 3 | PORCH GABLE | Again ensuring that the gable framework is rubbered-up follow the diagrams to assemble each gable in the building. Make sure that you have inserted the extra bolts utilised in sections 5 and 6. On the roof and side corner bars not every rubber channel will require rubber unless it is to be utilised in a partition (see separate manual and section P). |
| 3 | END GABLES | |
| 4 | PORCH SIDES | The porch sides (the L-shaped area to the left and right of the porch gable between cills and gutters level) can either be built in situ piece by piece or built away from the structure as an L-shape and then attached in a similar manner to plain gable/s to rear. Please ensure that where relevant you slide 2 x 22mm bolts into the side bars for the attachment of the DV100 eaves spandrels. |
| 5 | MAIN FRAME ASSEMBLY | Take the rear and any handed side extensions (1) and the end gables (3) and join them together on your wall. It is a good idea to tie some ladders to the sides to support them if you do not have anyone to hold them for you. Once the porch sides (4) have been attached to the main building then the porch gable (2) can be inserted between them in the same way you would attach an end gable to the rear. You will now have a T-shaped framework. It is important that you check that the internal diagonal measurements within the building are equal to ensure that the building is square, spending a little time on this now will speed up roof assembly and glazing. On buildings longer than 12' the end gables (3) should attach to the extension sides first before the 12' rear side maintaining 620mm spacings, e.g. a 20' building = end (3), 4' handed extension sides, 12' rear (1), 4' handed extension sides, end (3). |
| 6a | MAIN ROOF | Attach the main ridge between the end gables and then the rubbered-up roof bars 'DV277' ensuring that they are fully butted up to the ridge. Ensure the correct number and length of bolts have been slid into each bar before fixing them down onto the gutter. Attach your cresting before you glaze the building to give yourself more room to work. Utilise the 22mm bolts slid into the rear (section 1) and roof bars to attach your DV100 and DV101 spandrels. On longer models you may need to carefully prop up the roof and tie the sides together to keep the ridge and gutters straight (i.e. not sagging or bowed) until the building is fully glazed. |
| 6b | PORCH ROOF | The porch ridge can be fitted to the porch gable supporting its free end with ladders or a wooden sprag. The porch hips 'DV570' can now be attached between the welded porch gutter sections and the free end of the porch ridge. A 'lower' height porch utilises a DV380 bracket to allow the porch ridge to connect to the main module. Identify all of the handed roof bars and look for their locations. Insert the rubber into their channels and when attaching ensure again that were relevant you slide in 22mm bolts for eave (x2) and roof spandrels (x2). Eave and Roof spandrels can now be attached using the previously inserted 22mm bolts. The ladders / sprag supporting the porch ridge free end can now be removed. Prior to glazing the cresting and finials should be siliconed into place. Attaching them once the glass has been installed by leaning through vent apertures is more time consuming. |
| 7 | VENT | Once the vent is glazed add silicone to the vent sides and top. Stand the vent/s on their hinge (vent top) and then leave the silicone to set. The vent slam bar 'D079' can be moved up and down between the roof glazing bars so that it can be butted down onto the pane of glass beneath, the autovent will be attached to it later on (10). |
| 8 | LOUVRE | They attach to the building during the glazing process (9) like a piece of glass with a black separator above them. If you are fitting an optional auto-louvre then you need to carefully drill (3mm bit) out the rivets which mount the handle to the frame. You can then either utilise those holes or create more to mount the unit. An auto louvre can NOT be fitted if an A-frame vertical is directly adjacent to the louvre handle. |
| 9 | GLAZING | Layout the bar cappings and covers around the building like a sundial checking that all is present and correct. You can also place the roof cappings in the gutters so they are closer to hand. Use the capping and the self tapping screws to then hold the glass in place. The covers then enclose the screw heads giving a neat finish. It is a good idea to glaze two diagonally opposite end roof sections first to ensure the building is square followed by two side sections to ensure the building isn't leaning. We would then recommend that you glaze the porch roof and its adjoining angled roof panes whilst the building still has some movement in it. IMPORTANT: The porch cowling 'DV341' should be attached before the vents are inserted so that access through vent apertures is available. Silicone the cowling area internally, position cowl and VERY carefully (avoiding glass below) mark, drill and screw x 2 'FS6018' into place. Silicone the cowling externally and check with a watering can that the cowl is water tight, note silicone can be moulded shortly after application if you wet your fingers. IMPORTANT: On the roof sections please make sure that you place a screw around 25mm / 1" from the bottom of each capping strip (create a hole in the plastic if required) and that the screws are nice and tight to avoid any glass slippage. On the roof there are three panes, glaze from the gutter upwards with the two smaller upper panes each overlapping the lower by 10-15mm. The roof capping comes in three sections which should allow for the overlap and stop the upper panes from sliding down. The roof cover then canopies the three caps in one long length. |
| 10 | VENT ATTACHMENT | Take the assembled vent and slide the vent hinge 'D866' into the end of the ridge allowing the vent to pivot open and closed. Vent stops 'D220' go either side of the vent to stop any lateral movement (so insert stop / vent / stop). Any extra D220 barrel stops supplied with any a-frames can also be fitted at this point at ridge joints to help to keep them in perfect alignment. Attach the autovents. |
| 11 | DOOR ATTACHMENT | Your double doors come pre-constructed and locked minus the handles and their pivot pin but now it needs to be mounted to the porch front. Utilise the 'DV522' plates and twist in crop headed bolts to join the door and its frame to the building (pinch the door frame against your long front verticals whilst tightening your 'DV522' plates to ensure that there is no gap). If you are struggling to eradicate the gap between the door frame and verticals then some silicone can be carefully applied to the area to create a vertical seal. Be careful not to lock yourself in the building and to avoid damage do not open the doors until they are attached. Getting the doors to swing perfectly without dropping or rubbing on the ground may require some small but vital adjustments. You may also need to insert a packer underneath the door frame hinges to increase ground clearance. Part 'DV580' canopies the door frame top hiding the clearance space at the top of the door. The doors can only be made to swing inwards. IMPORTANT: Please do NOT let the doors slam open or closed as it is likely to cause damage to the doors and the frame. Please twist the handle to open and close. Please also be aware that your door KEYS (3 provided) are unique to the building so they should not be stored together. |
| 12 | ANCHORING DOWN | Now that the greenhouse is finished and the doors and vent/s are operating without interference then you need to anchor the building down using 2" rawl plugs and screws. Use a 7mm masonry bit in a hammer drill to create the holes. |
| 13 | FINISHING TOUCHES | Now that the main body of the structure is complete you can add; downpipe fittings, eave bungs, gutter stop ends. It is also important to carefully apply some silicone to the internal eaves corners and external and internal ridge corners to minimise the chance of water entering the structure. |
| 14 | OPTIONAL REAR SHELIVING | Robinsons integral cantilever staging and shelving attaches to the inside of the greenhouse frame using either square / hex head bolts (insert four into each side glazing bar 'D609' during construction of the rear (1)) or rectangular 'crop head' bolts which can be fitted retrospectively (both sets of bolts accompany the shelving/staging). This system allows the height of either the staging or the shelf to be set at a user specific height. Commonly the staging brackets are set 900mm from the finished floor level though you can alter this to suit the end user/s. The aluminium shelf / staging slats come in two lengths; (4):1240mm 'D2002' and (6):1860mm 'D2003'. These slats can combine to create any length of staging required, i.e. 4'+6' = 10' etc.. |
| 15 | OPTIONAL REAR STAGING | |

| Section Ref | Part No. | Section | Size (mm) | 19 12 | 19 20 | 19 28 | 19 36 | 19 44 |
|-------------|----------|---------|-----------|-------|-------|-------|-------|-------|
|-------------|----------|---------|-----------|-------|-------|-------|-------|-------|

| | | | | | | | | |
|---|-----------------------|--|------|-----|-----|-----|-----|-----|
| MAIN FRAME QUANTITIES VENTS / DOORS etc SEPERATE | FS6505 HEX 12mm | | 12mm | 215 | 255 | 279 | 305 | 329 |
| | FS6506 HEX 16mm | | 16mm | 55 | 63 | 71 | 79 | 87 |
| | FS6507 HEX 22mm | | 22mm | 84 | 108 | 156 | 180 | 204 |
| | HE569 CROP BOLT | | 10mm | 24 | 28 | 36 | 44 | 52 |
| | FS6504 M6 NUT | | M6 | 384 | 486 | 574 | 672 | 736 |
| | FS6006 | | 35mm | 6 | 32 | 64 | | |

| | | | | | | | | | |
|----------|----------|--|--------------|----|-----|-----|-----|-----|--|
| 1 | D023 | | 3754 | 1 | | | | | |
| | D024L/R | | 2480 | | | 2+2 | 2+2 | 4+4 | |
| | D075L/R | | 1240 | | 2+2 | | 2+2 | | |
| | DV212 | | 3757 | 1 | | | | | |
| | DV214L/R | | 2480 | | | 2+2 | 2+2 | 4+4 | |
| | DV241L/R | | 1240 | | 2+2 | | 2+2 | | |
| | D604 | | 1316 | 2 | 4 | | | | |
| | D609 | | 1160 | 5 | 13 | 21 | 29 | 37 | |
| | RUBBER | | 1000 (1m) | 12 | 31 | 49 | 68 | 86 | |
| | D174 | | N/A | 5 | 9 | 17 | 21 | 29 | |







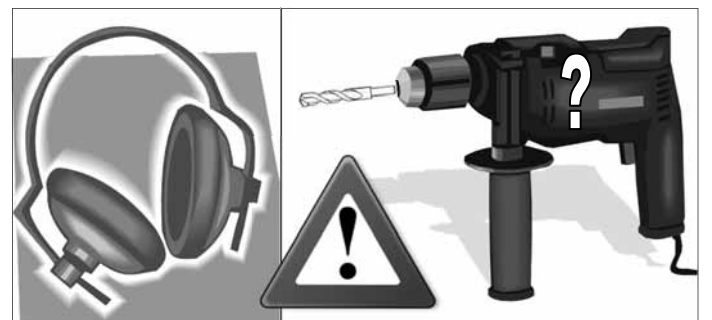



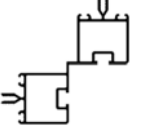
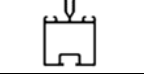
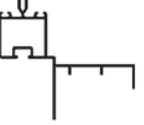
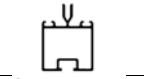

| Section Ref | Part No. | Section | Size (mm) | 19 12 | 19 20 | 19 28 | 19 36 | 19 44 |
|-------------|----------|---------|-----------|-------|-------|-------|-------|-------|
|-------------|----------|---------|-----------|-------|-------|-------|-------|-------|

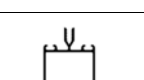
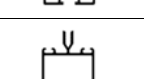
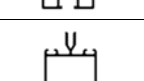

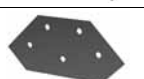

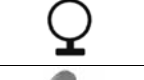





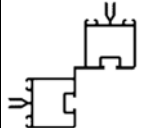
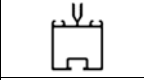
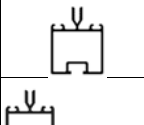
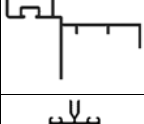

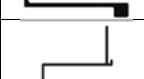
| | | | | | | | | |
|----------|--------|--------------|------|-----|---|--|--|--|
| 2 | DV594 | | 1470 | 2 | | | | |
| | D608 | | 1160 | 2 | | | | |
| | DV066L | | 1505 | 1 | | | | |
| | DV066R | | | 1 | | | | |
| | DV252L | | 2451 | 1 | | | | |
| | DV252R | | | 1 | | | | |
| | DV264 | | 1398 | 1 | | | | |
| | DV270L | | 782 | 1 | | | | |
| | DV270R | | | 1 | | | | |
| | DV307 | | 1350 | 2 | | | | |
| | DV310L | | 1972 | 1 | | | | |
| | DV310R | | | 1 | | | | |
| | DV580 | | 1838 | 1 | | | | |
| | DV582L | | 946 | 1 | | | | |
| | DV582R | | | 1 | | | | |
| | DV591L | | 1019 | 1 | | | | |
| | DV591R | | | 1 | | | | |
| | DV592L | | | 191 | 1 | | | |
| | DV592R | 1 | | | | | | |
| | DV104 | | N/A | 2 | | | | |
| DV105 | | N/A | 1 | | | | | |
| D163 | | 90 | 2 | | | | | |
| RUBBER | | 1000 (1m) | 36 | | | | | |
| D174 | | N/A | 6 | | | | | |

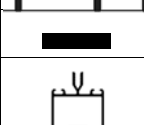
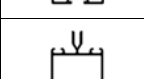

| Section Ref | Part No. | Section | Size (mm) | 19 12 | 19 20 | 19 28 | 19 36 | 19 44 |
|-------------|----------|---------|-----------|-------|-------|-------|-------|-------|
|-------------|----------|---------|-----------|-------|-------|-------|-------|-------|

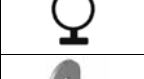





| | | | | | | | | |
|-----------|---|---|-----------|--|--|----|----|--|
| 3P | D608 |  | 1160 | | | | 2 | |
| | DV066L |  | 1505 | | | | 1 | |
| | DV066R | | | | | | 1 | |
| | DV238L |  | 3111 | | | | 1 | |
| | DV238R | | | | | | 1 | |
| | DV258 |  | 3342 | | | | 1 | |
| | DV268 |  | 964 | | | | 1 | |
| | DV276 |  | 4336 | | | | 1 | |
| | DV291 |  | 4482 | | | | 1 | |
| | DV307 |  | 1350 | | | | 2 | |
| | DV310L |  | 1972 | | | | 1 | |
| | DV310R | | | | | | 1 | |
| | DV312L |  | 2438 | | | | 1 | |
| | DV312R | | | | | | 1 | |
| | DV319L |  | 2905 | | | | 1 | |
| | DV319R | | | | | | 1 | |
| | DV104 |  | N/A | | | | 2 | |
| | DV105 |  | N/A | | | | 1 | |
| | D982 |  | 106 | | | | 1 | |
| | RUBBER |  | 1000 (1m) | | | | 53 | |
| D174 |  | N/A | | | | 11 | | |



| Section Ref | Part No. | Section | Size (mm) | 19 12 | 19 20 | 19 28 | 19 36 | 19 44 |
|-------------|----------|---------|-----------|-------|-------|-------|-------|-------|
|-------------|----------|---------|-----------|-------|-------|-------|-------|-------|

| | | | | | | | | |
|-----------|---|---|------|--|--|----|---|--|
| 3D | D608 |  | 1160 | | | | 2 | |
| | DV066L |  | 1505 | | | | 1 | |
| | DV066R | | | | | | 1 | |
| | DV236L |  | 3430 | | | | 1 | |
| | DV236R | | | | | | 1 | |
| | DV238L |  | 3111 | | | | 1 | |
| | DV238R | | | | | | 1 | |
| | DV265 |  | 1865 | | | | 1 | |
| | DV268 |  | 964 | | | | 1 | |
| | DV275 |  | 904 | | | | 1 | |
| | DV278L |  | 1716 | | | | 1 | |
| | DV278R | | | | | | 1 | |
| | DV299L |  | 1786 | | | | 1 | |
| | DV299R | | | | | | 1 | |
| | DV307 |  | 1350 | | | | 2 | |
| | DV310L |  | 1972 | | | | 1 | |
| | DV310R | | | | | | 1 | |
| | DV312L |  | 2438 | | | | 1 | |
| | DV312R | | | | | | 1 | |
| | DV104 |  | N/A | | | | 2 | |
| DV105 |  | N/A | | | | 1 | | |
| D163 |  | 90 | | | | 2 | | |
| D982 |  | 106 | | | | 1 | | |
| RUBBER |  | 1000 (1m) | | | | 51 | | |
| D174 |  | N/A | | | | 8 | | |

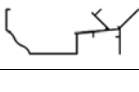













19' Rufford Victorian

| Section Ref | Part No. | Section | Size (mm) | 19 12 | 19 20 | 19 28 | 19 36 | 19 44 |
|-------------|----------|---------|-----------|-------|-------|-------|-------|-------|
|-------------|----------|---------|-----------|-------|-------|-------|-------|-------|

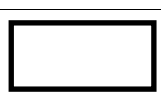
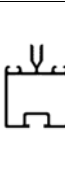
| | | | | | | | | |
|----------|--------|---|------------|--|--|----|--|--|
| 4 | D604 |  | 1316 | | | 2 | | |
| | D609 |  | 1160 | | | 4 | | |
| | DV363 |  | 1160 | | | 2 | | |
| | DV558 | | 143 | | | 1 | | |
| | DV559 |  | 143 | | | 1 | | |
| | DV574 | | 1383 | | | 1 | | |
| | DV575 | | 1383 | | | 1 | | |
| | DV578 | | | | | 1 | | |
| | DV579 |  | 165 x 1407 | | | 1 | | |
| | RUBBER |  | 1000 (1m) | | | 14 | | |
| | D174 |  | N/A | | | 6 | | |

| | | | | | | | | |
|----------|-------|---|-----|--|--|---|--|---|
| 5 | DV227 |  | N/A | | | 4 | | 8 |
| | D114 |  | N/A | | | 4 | | 8 |

| Section Ref | Part No. | Section | Size (mm) | 19 12 | 19 20 | 19 28 | 19 36 | 19 44 |
|-------------|----------|---------|-----------|-------|-------|-------|-------|-------|
|-------------|----------|---------|-----------|-------|-------|-------|-------|-------|







| | | | | | | | | | |
|----------|----------|---|---|-----------|----|-------|-----|-----|-----|
| 6 | D982 |  | 106 | | | 4 | | | |
| | DV100 |  | N/A | 9 | 13 | 21 | 25 | 33 | |
| | DV101 |  | N/A | 12 | 14 | 18 | 20 | 24 | |
| | DV153 |  | N/A | | | 8 | | 16 | |
| | DV203 |  | 3757 | | | 1 | | | |
| | DV206 | | 2480 | | | 2 | 2 | 4 | |
| | DV240 | | 1240 | | 2 | | 2 | | |
| | DV352 | | 3090 | | 1 | | | | |
| | DV255 |  | 2450 | | | 4 | | | |
| | DV277 |  | 3110 | 5 | 13 | 21 | 29 | 37 | |
| | D114 |  | N/A | | | 4 | | 8 | |
| | D137 |  | 2176 | | | 2 | | | |
| | DV365 | | 882 | 1 | 3 | | 5 | | |
| | DV297 |  | 2832 | | | 2 | | 4 | |
| | DV298 | | 1772 | | | 4 | | 8 | |
| | DV375L/R |  | 830 | | | 1 + 1 | | | |
| | DV376L/R | | 1708 | | | 1 + 1 | | | |
| | DV377L/R | | 1492 | | | 1 + 1 | | | |
| | DV378L/R | | 2368 | | | 1 + 1 | | | |
| | DV380 |  | N/A | | | 1 | | | |
| | DV383 |  | 661 | | | 1 | | | |
| | DV570 |  | 3018 | | | 2 | | | |
| | DV279 |  | 3036 | | | 4 | | | |
| | D596 | | 3757 | | | 2 | | | |
| | D598 | | 2480 | | | | 4 | 4 | 8 |
| | D599 | | 1240 | | | 4 | | 4 | |
| | DV597 | | 1114 | | | 4 | | 8 | |
| | D855 | |  | N/A | | | 4 | | 8 |
| | RUBBER | |  | 1000 (1m) | 79 | 128 | 178 | 228 | 279 |



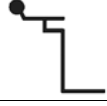
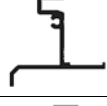

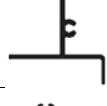
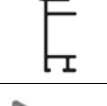
19' Rufford Victorian

| Section Ref | Part No. | Section | Size (mm) | 19 12 | 19 20 | 19 28 | 19 36 | 19 44 |
|-------------|----------|---------|-----------|-------|-------|-------|-------|-------|
|-------------|----------|---------|-----------|-------|-------|-------|-------|-------|

| Section Ref | Part No. | Section | Size (mm) | 19 12 | 19 20 | 19 28 | 19 36 | 19 44 |
|-------------|----------|---------|-----------|-------|-------|-------|-------|-------|
|-------------|----------|---------|-----------|-------|-------|-------|-------|-------|

| | | | | | | | | |
|---|------------------------|--|-----|----|----|----|----|----|
| 7 | D866 |  | 639 | 6 | 10 | 12 | 16 | 18 |
| | D863L |  | 613 | 6 | 10 | 12 | 16 | 18 |
| | D863R |  | 613 | 6 | 10 | 12 | 16 | 18 |
| | D862 |  | 593 | 6 | 10 | 12 | 16 | 18 |
| | D079 PLUS FLUFF |  | 590 | 6 | 10 | 12 | 16 | 18 |
| | D114 |  | N/A | 12 | 20 | 24 | 32 | 18 |
| | D220 PLUS FS6060 SCREW |  | N/A | 12 | 20 | 24 | 32 | 18 |
| | D205 |  | N/A | 12 | 20 | 24 | 32 | 18 |

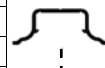
| | | | | | | | | | | |
|---|----------|----------|---|---|----------|----------|----|----|----|----|
| 8 | 1 | D618 |  | 1144 | 13 | 17 | 21 | 25 | 29 | |
| | 5 | D870 | | 601 | 13 | 21 | 29 | 37 | 45 | |
| | 5 | D883 | | 662 | 7 | 15 | 23 | 31 | 39 | |
| | 2/3 | DV403L/R | | 1505 | 3 + 3 | | | | | |
| | 10 | DV479 | | 1384 | 2 FITTED | | | | | |
| | 2 | DV583L/R | | 921 | 1 + 1 | | | | | |
| | 2 | DV595 | | 1470 | 2 | | | | | |
| | 2/3 | DV610L/R | | 1972 | 3 + 3 | | | | | |
| | 2/3 | DV612L/R | | 2438 | 2 + 2 | | | | | |
| | 3 | DV616L/R | | 2905 | 2 + 2 | | | | | |
| | 3 | DV641 | | 3342 | 2 | | | | | |
| | 5 | DV655 | | 1880 | 9 | 17 | 25 | 33 | 41 | |
| | 2 | DV664 | | 1373 | 1 | | | | | |
| | 5 | DV675L/R | | 863 | 1 + 1 | | | | | |
| | 5 | DV676L/R | | 1741 | 1 + 1 | | | | | |
| | 5 | DV677L/R | | 924 | 1 + 1 | | | | | |
| | 5 | DV678L/R | | 1799 | 1 + 1 | | | | | |
| | 5 | DV683 | | 680 | 1 | | | | | |
| | 2/3 | D610 | |  | 1160 | 6 | | | | |
| | 1/4 | D620 | | | 1144 | 6 | | | | |
| | 5 | D871 | | | 601 | 6 | | | | |
| | 5 | DV630 | | | 660 | 4 | | | | |
| | 5 | DV652 | | | 1871 | 6 | | | | |
| | 2/3 | D614 | |  | 1162 | 6 | | | | |
| | 1/4 | D619 | | | 1144 | 19 | 23 | 27 | 31 | 35 |
| | 10 | DV480 | | | 1384 | 2 FITTED | | | | |
| | 2 | DV584L/R | | | 921 | 1 + 1 | | | | |
| | 2 | DV596 | | | 1470 | 2 | | | | |
| | 2/3 | DV611L/R | | | 1972 | 3 + 3 | | | | |
| | 2/3 | DV613L/R | | | 2438 | 2 + 2 | | | | |
| | 2/3 | DV615L/R | | | 1505 | 3 + 3 | | | | |
| | 3 | DV617L/R | | | 2905 | 2 + 2 | | | | |
| 5 | DV632 | 3144 | 9 | | 17 | 25 | 33 | 41 | | |
| 3 | DV642 | 3342 | 2 | | | | | | | |
| 5 | DV658 | 2481 | 6 | | | | | | | |
| 2 | DV670 | 1373 | 1 | | | | | | | |
| 5 | DV679L/R | 863 | 1 + 1 | | | | | | | |
| 5 | DV680L/R | 1741 | 1 + 1 | | | | | | | |
| 5 | DV681L/R | 1525 | 1 + 1 | | | | | | | |
| 5 | DV682L/R | 2400 | 1 + 1 | | | | | | | |
| 5 | DV684 | 680 | 1 | | | | | | | |

UPDATE: Robinsons plastic / aluminium cover strips -

On a Robinsons building the glazing capping is in two parts. The lower plastic capping screws into the glazing bars pressing the glass down onto its rubber beading. The upper plastic / aluminium covers then need to be applied to cover the heads of the self-tapping screws. If you are struggling to press on the cover strips then we recommend the use of a rubber mallet or perhaps a wooden block and hammer, a short sharp tap onto the cover at one end is all that is needed to stretch the cover around the lower capping protrusions locking it into place. You can then either continue to use the mallet along the length of the cover or continue just using the palm of your hand. Once in the building and the edges are protected Robinsons 4mm thick toughened safety glass is very strong and can cope with the vibrations caused by hitting the covers though we would not recommend that you hit the glass directly. Some of the aluminium cover caps have a hole in them at one end which is sometimes used to hang the parts for powder coating. You can if you wish use the hole to stop the covers from sliding in the roof using a glazing screw, note you will have to use a countersunk screw under the vents to avoid interference with the vent bottom.

| | | | | | | | | |
|----|------|---|-----|----|--|--|--|--|
| 11 | D522 |  | N/A | 10 | | | | |
|----|------|---|-----|----|--|--|--|--|

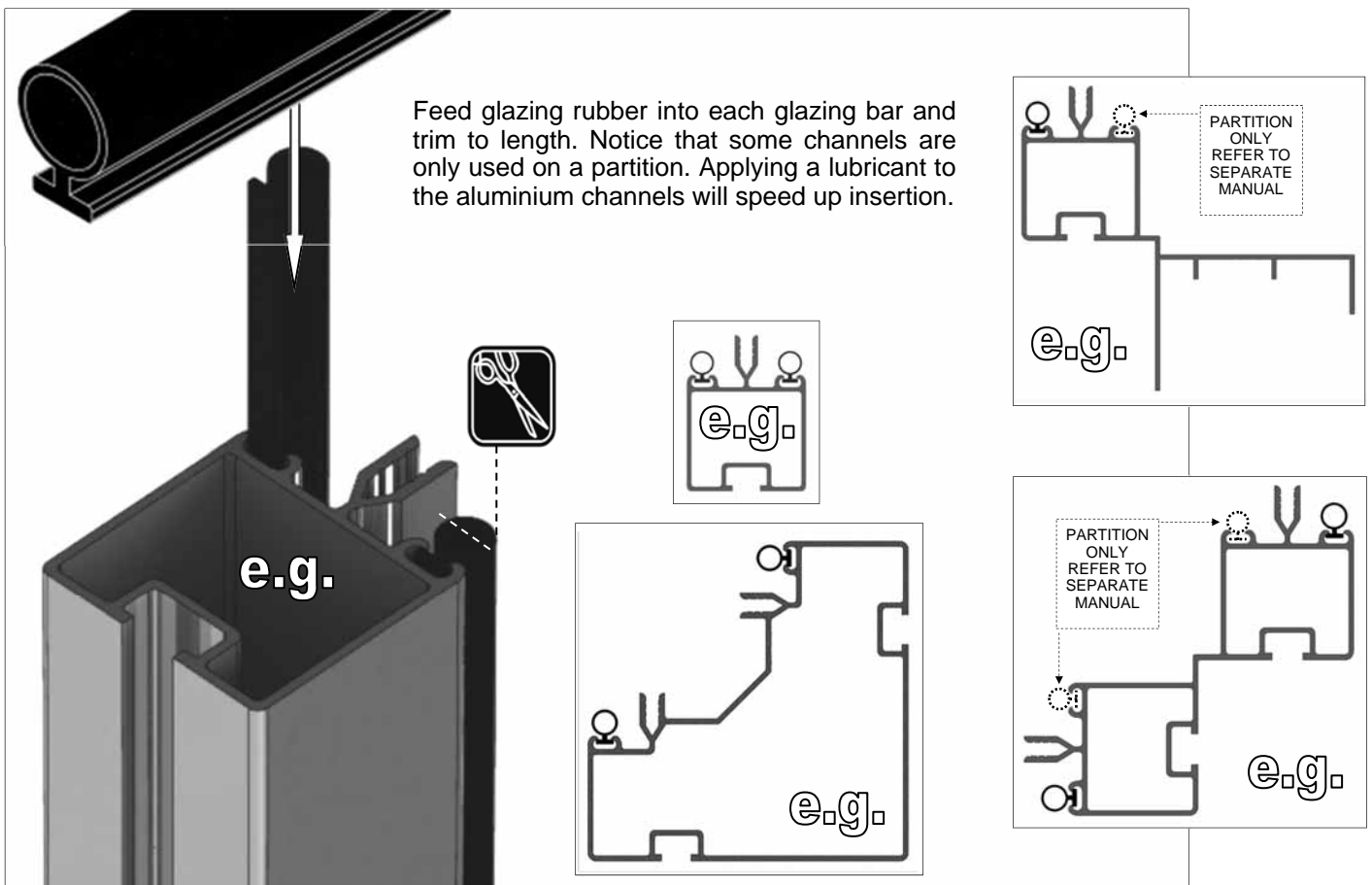

Robinsons have now upgraded the original square headed alloy bolts to stainless steel Hexagonal headed bolts. The frame is assembled by feeding these bolts, either 12mm, 16mm or 22mm in length (previously 10mm, 15mm and 22mm) into the slots on glazing bars and then locating those bolts through holes in purlings and cills, etc... The 12mm bolts tend to be used to join two parts together and the 16mm bolts tend to be used to join two or more parts or where an extrusion is thicker. 22mm bolts are for your eave and ridge spandrels (DV100 / DV101).

Twist in (rectangular) crop headed bolts are also used towards the end of construction to attach components to the frame retrospectively when the glazing bar slots are no longer exposed at the ends.

If an image in the manual shows a square headed bolt please interpret it as the new HEX headed replacement.



| | ORIGINAL SQUARE HEAD | | NEW HEX HEAD |
|------|----------------------|------|--------------|
| 10mm | | 12mm | |
| 15mm | | 16mm | |
| 22mm | | 22mm | |

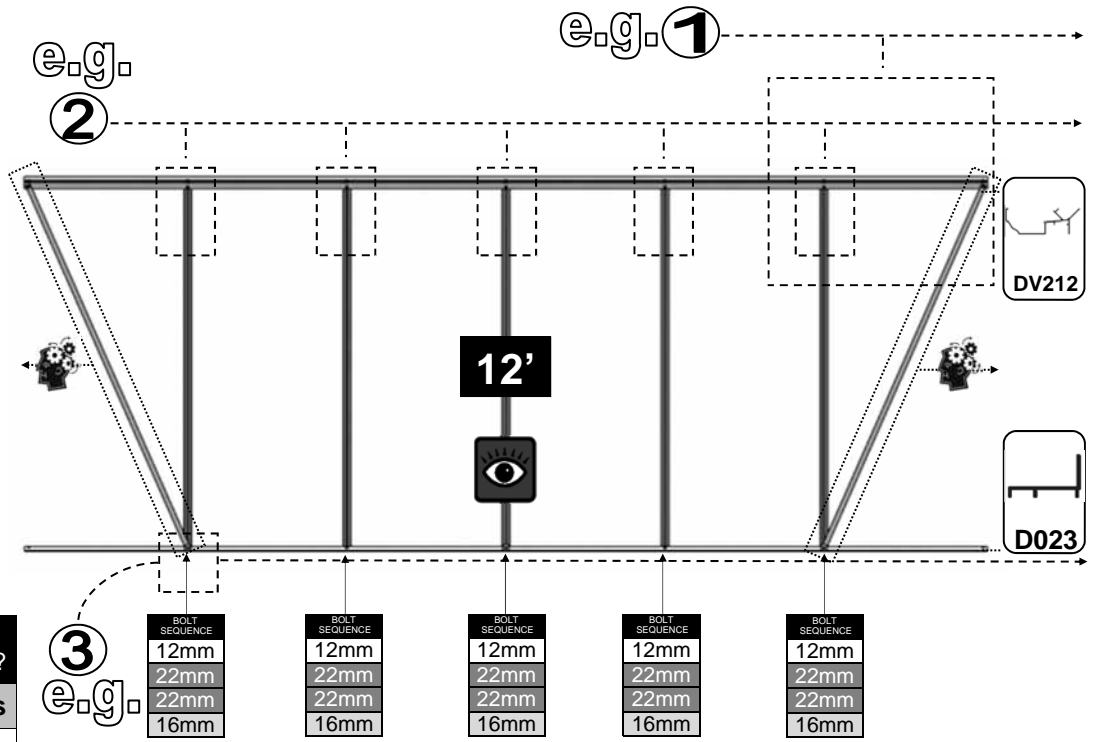

| REAR | | 19 x 12 |
|-------------------|---|----------|
| Part No | mm | Quantity |
| DV212 | 3757 | 1 |
| D023 | 3754 | 1 |
| D609 | 1160 | 5 |
| D604 | 1316 | 2? |
| D174 |  | 5 |
| FS6505 HEX12mm |  | 5 |
| FS6506 HEX16mm |  | 7 |
| FS6507 HEX22mm |  | 10 |
| FS6504 M6NUT |  | 12 |
| D227 Rubber |  | 12 |



2 x 4'LH and 2 x 4' RH and / or 2 x 8'LH and 2 x 8' RH extension sides?

| 12'+ MODELS | 4' EX's | 8' EX's | |
|-------------------|---|----------|----|
| Part No | mm | Quantity | |
| D024L | 2480 | 2 | |
| D024R | 2480 | 2 | |
| D075L | 1240 | 2 | |
| D075R | 1240 | 2 | |
| D604 | 1316 | 2 | |
| D609 | 1160 | 8 | 16 |
| DV214L | 2480 | 2 | |
| DV214R | 2480 | 2 | |
| DV241L | 1240 | 2 | |
| DV241R | 1240 | 2 | |
| D174 |  | 4 | 12 |
| FS6505 HEX12mm |  | 4 | 12 |
| FS6506 HEX16mm |  | 8 | 16 |
| FS6507 HEX22mm |  | 8 | 24 |
| FS6504 M6NUT |  | 12 | 28 |
| D227 Rubber |  | 19 | 38 |

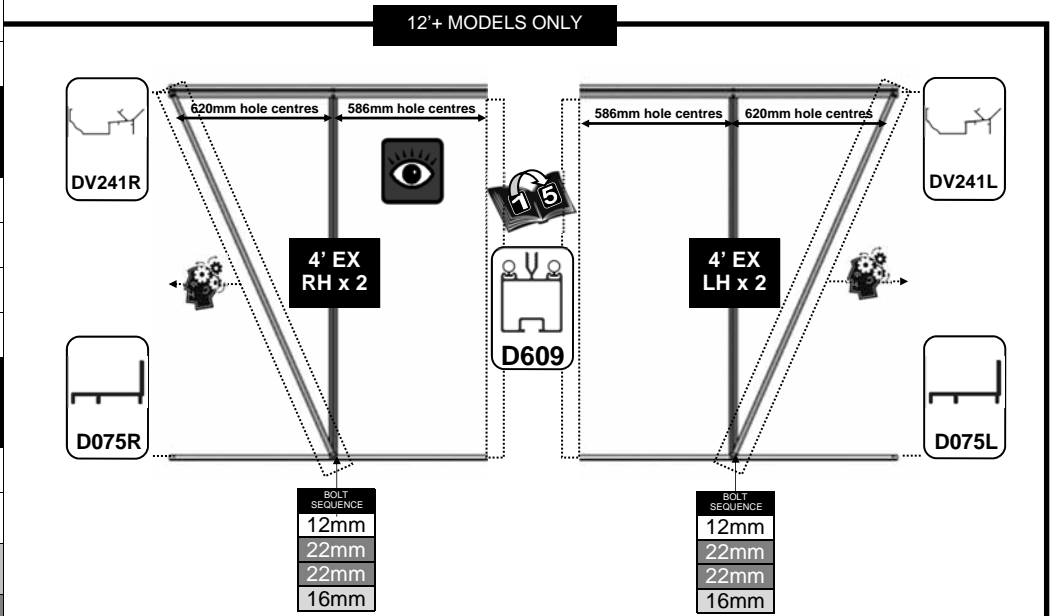

IMPORTANT 12'+ MODELS:
 Be careful not to mix up your extension cills and gutters. There will be a separate gutter and cill for the left and right side extensions. In addition one set of holes in both the gutter, cill sections are slightly closer together (586mm instead of 620mm).

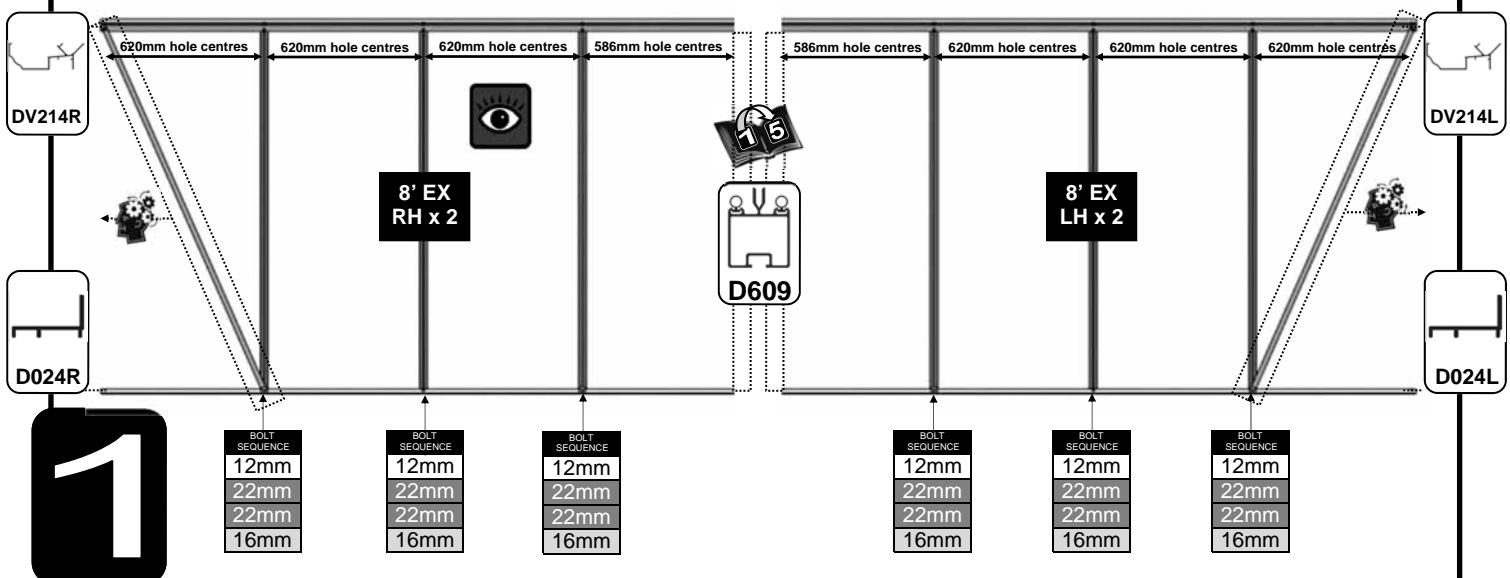

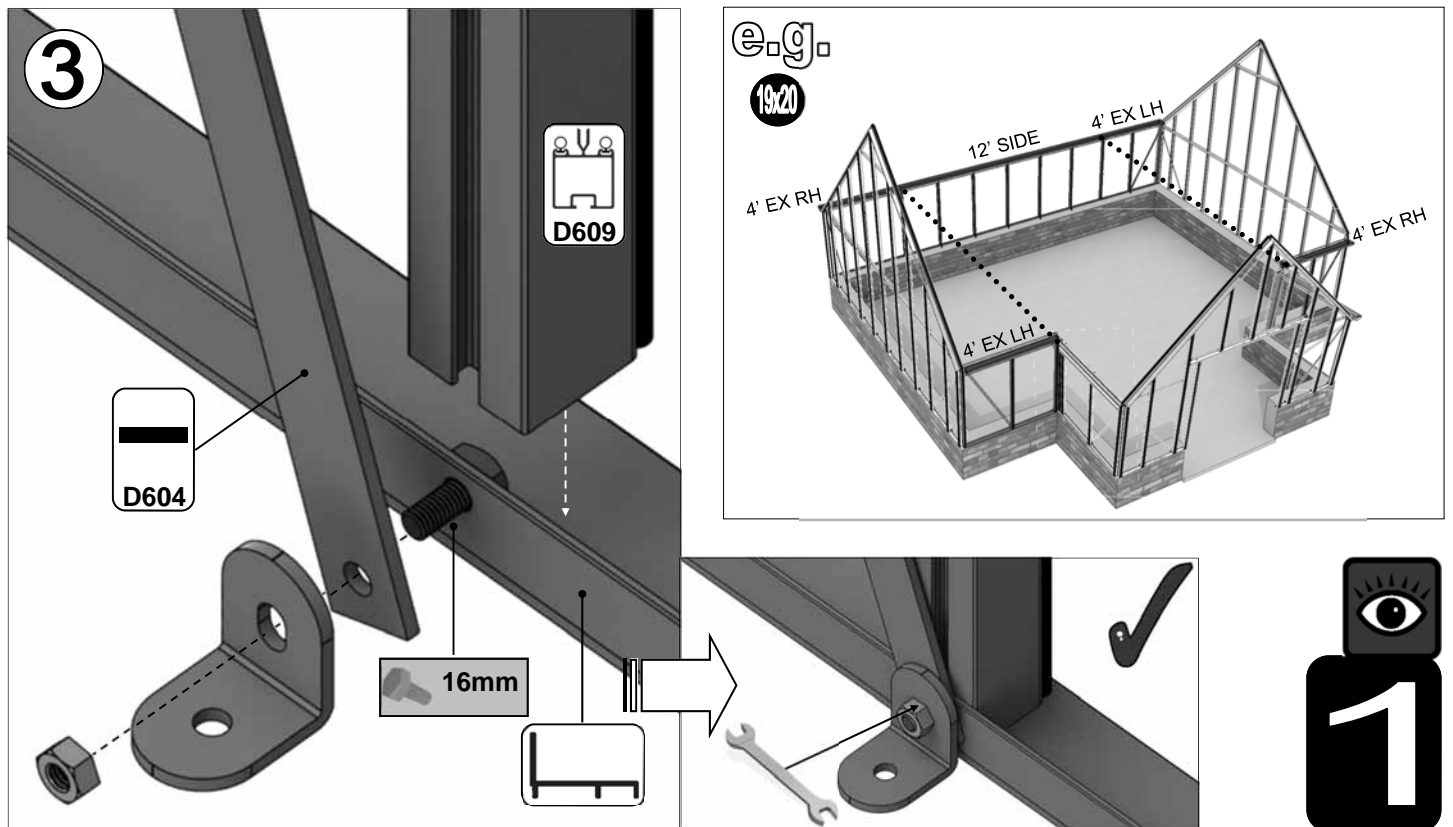
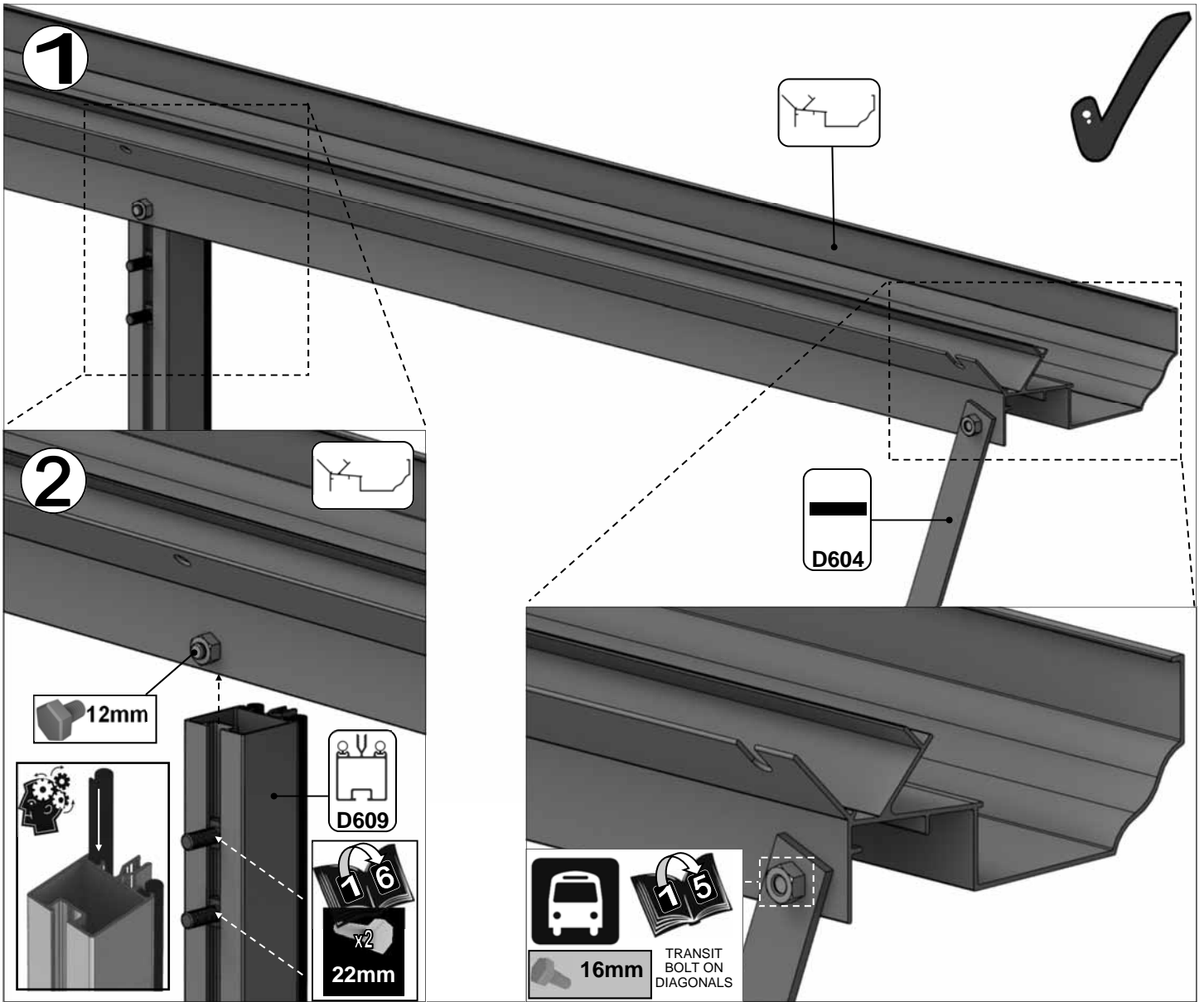

e.g.

19x20



| Part No | mm | Quantity |
|---------|------|----------|
| D608 | 1160 | 2 |
| DV066L | 1505 | 1 |
| DV066R | 1505 | 1 |
| DV252L | 2451 | 1 |
| DV252R | 2451 | 1 |
| DV264 | 1398 | 1 |
| DV270L | 782 | 1 |
| DV270R | 782 | 1 |
| DV307 | 1350 | 2 |
| DV310L | 1972 | 1 |
| DV310R | 1972 | 1 |
| DV580 | 1838 | 1 |

| Part No | mm | Quantity |
|--------------------|------|----------|
| DV582L | 946 | 1 |
| DV582R | 946 | 1 |
| DV591L | 1019 | 1 |
| DV591R | 1019 | 1 |
| DV592L | 191 | 1 |
| DV592R | 191 | 1 |
| DV594 | 1470 | 2 |
| DV104 | | 2 |
| DV105 | | 1 |
| D163 | | 2 |
| D174 | | 6 |
| D227 | | 36m |
| FS6505 HEX 12mm | | 40 |
| FS6506 HEX 16mm | | 14 |
| FS6507 HEX22mm | | 2 |
| FS6504 M6 NUT | | 54 |

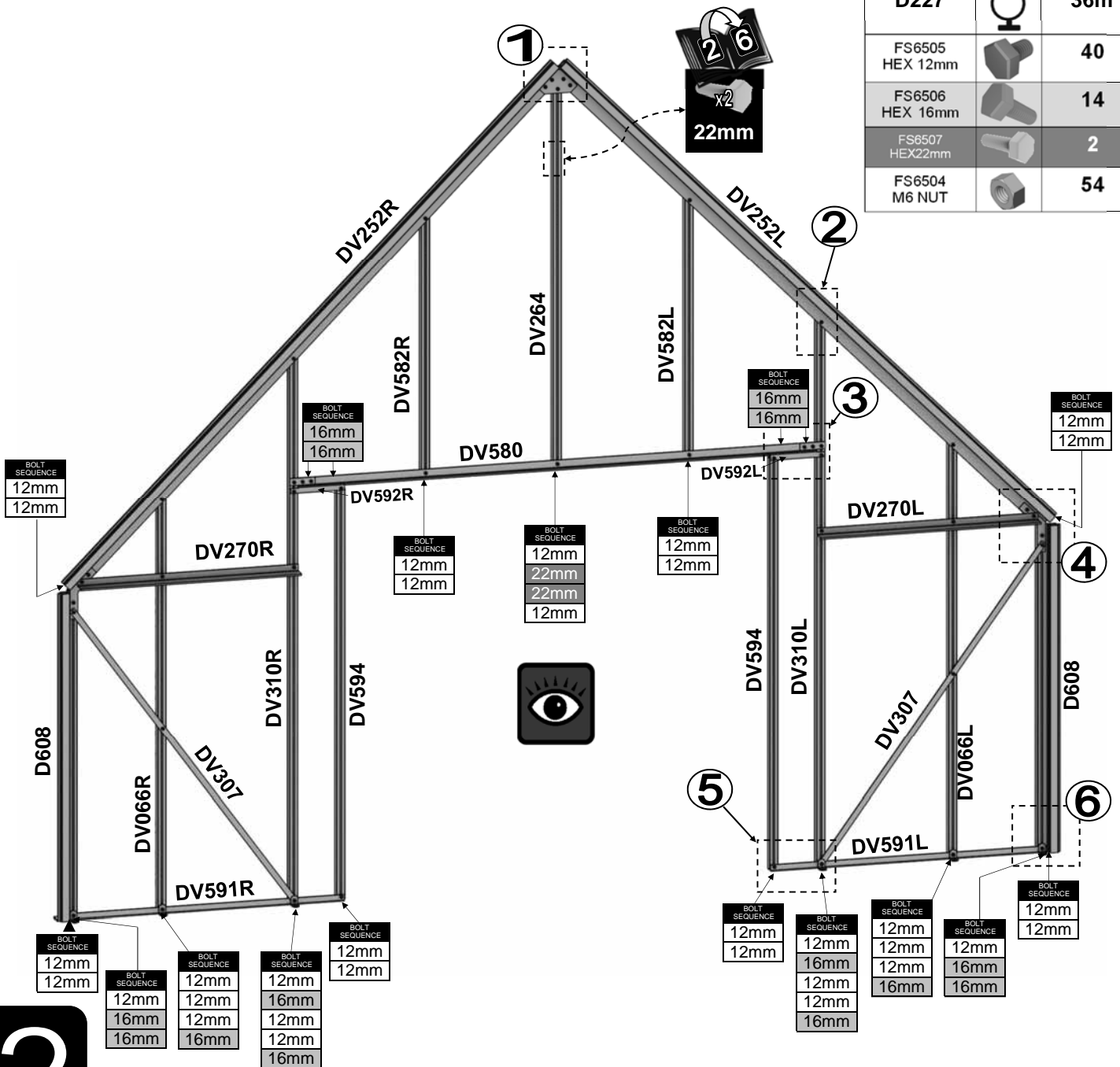

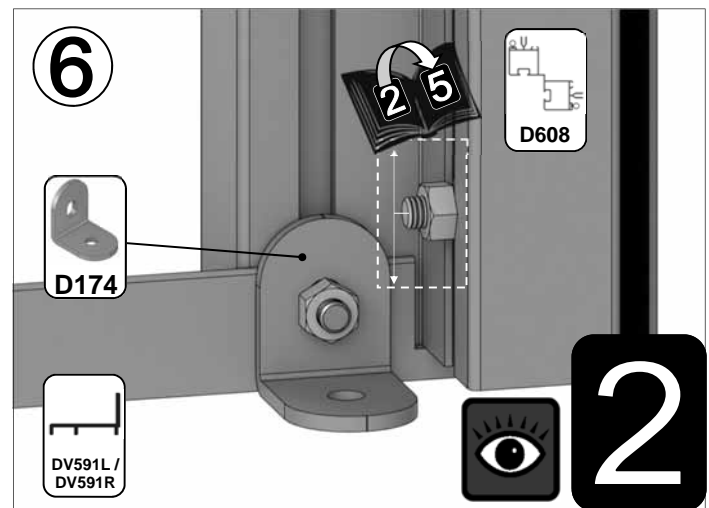
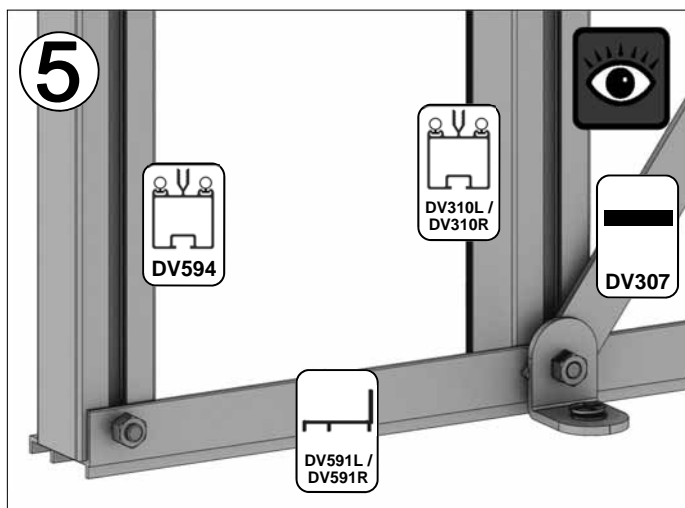
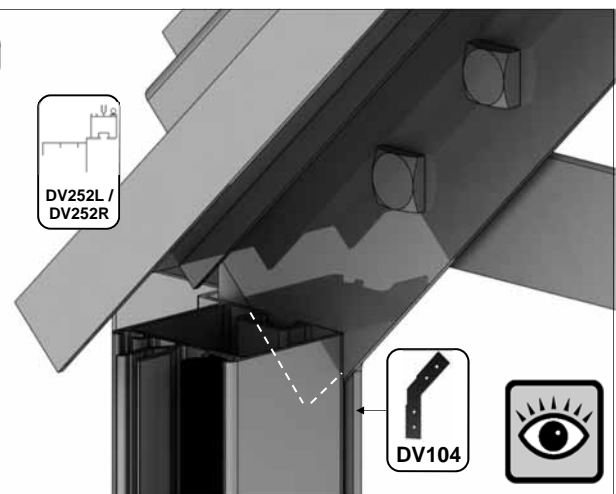
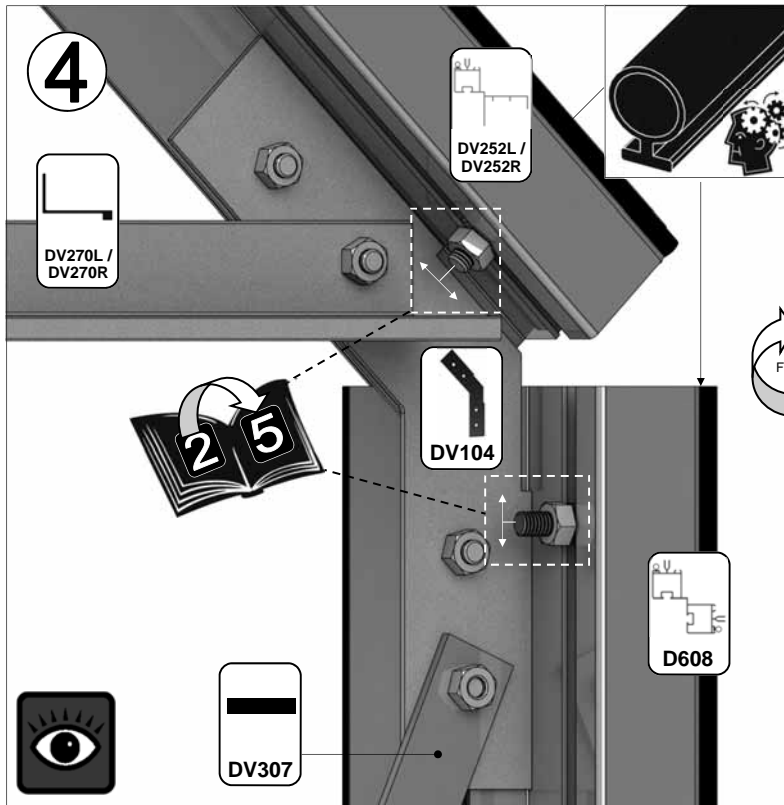
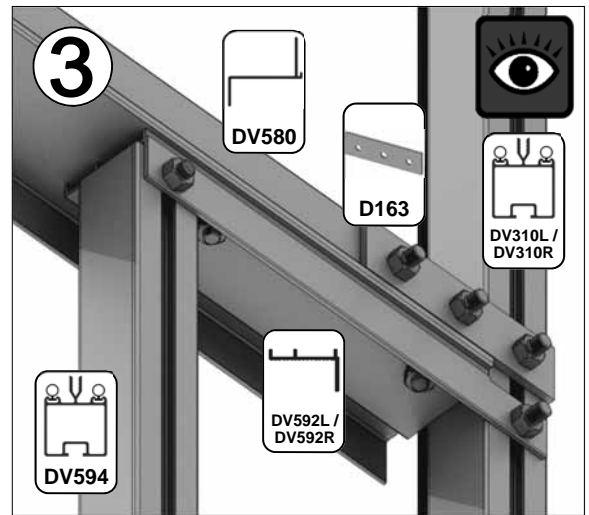
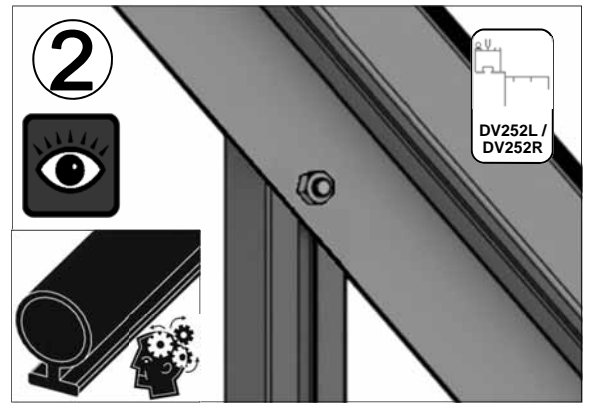
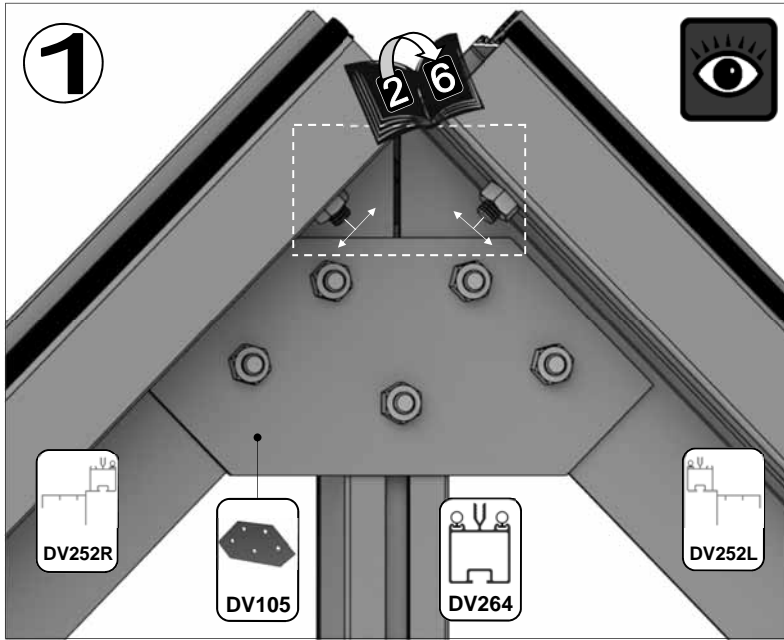

e.g.

19x20

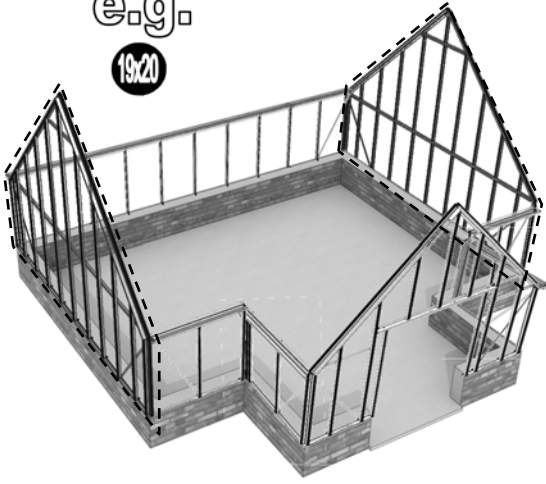

| Part No | mm | Quantity |
|---------|------|----------|
| D608 | 1160 | 2 |
| DV066L | 1505 | 1 |
| DV066R | 1505 | 1 |
| DV238L | 3111 | 1 |
| DV238R | 3111 | 1 |
| DV258 | 3342 | 1 |
| DV268 | 964 | 1 |
| DV276 | 4336 | 1 |
| DV291 | 4482 | 1 |
| DV307 | 1350 | 2 |

| Part No | mm | Quantity |
|--------------------|------|----------|
| DV310L | 1972 | 1 |
| DV310R | 1972 | 1 |
| DV312L | 2438 | 1 |
| DV312R | 2438 | 1 |
| DV319L | 2905 | 1 |
| DV319R | 2905 | 1 |
| DV104 | | 2 |
| DV105 | | 1 |
| D174 | | 11 |
| D982 | | 1 |
| D227 | | 53m |
| FS6505 HEX 12mm | | 41 |
| FS6506 HEX 16mm | | 13 |
| FS6507 HEX22mm | | 2 |
| FS6504 M6 NUT | | 54 |

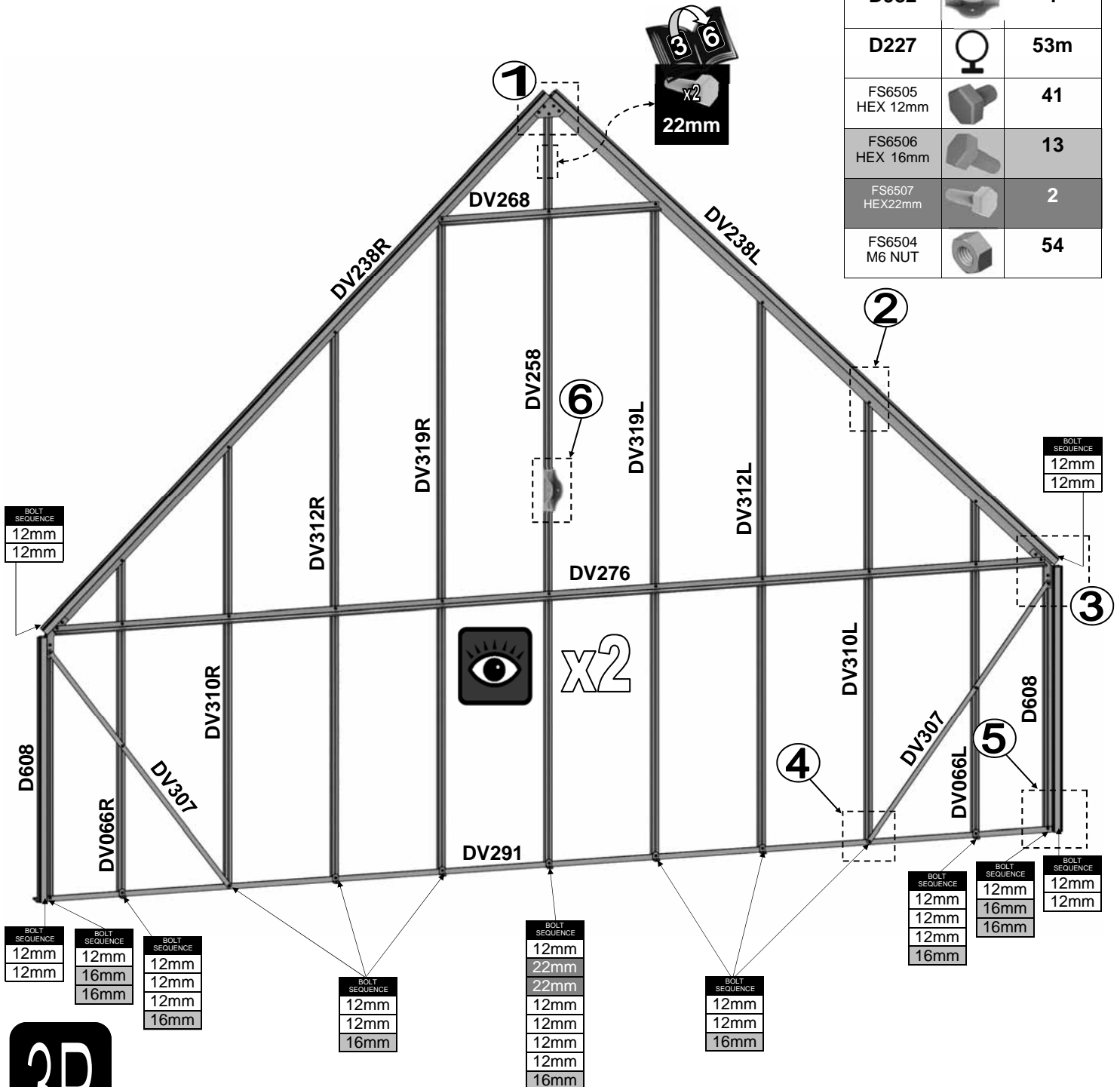

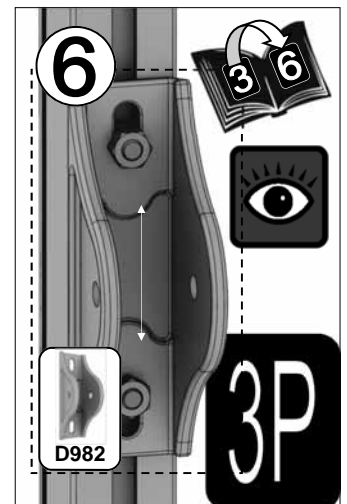
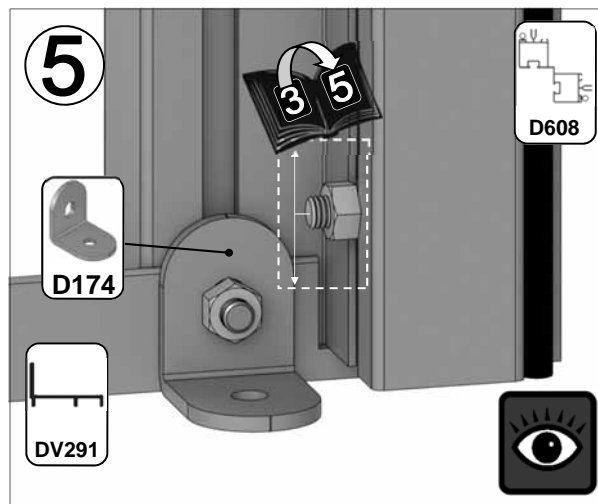
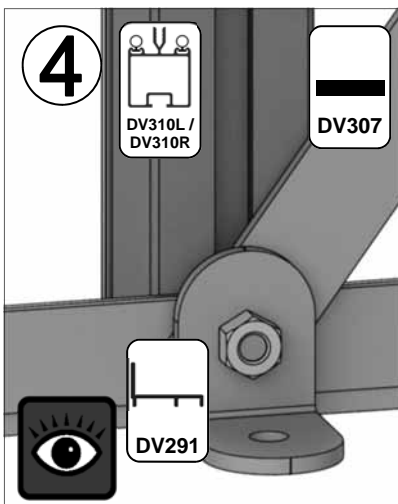
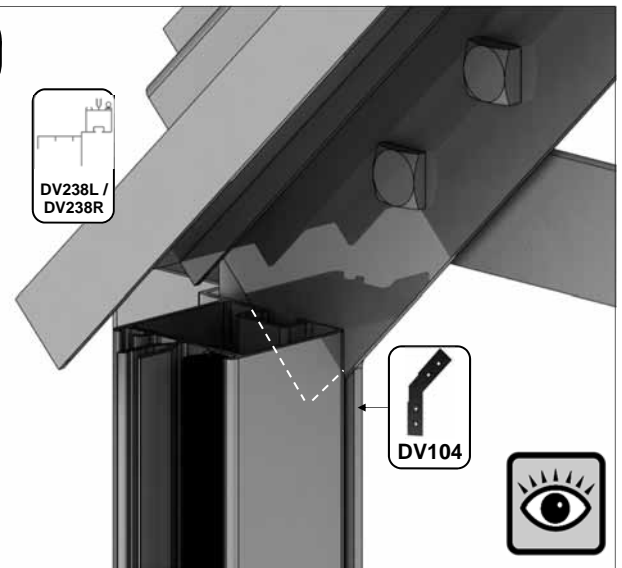
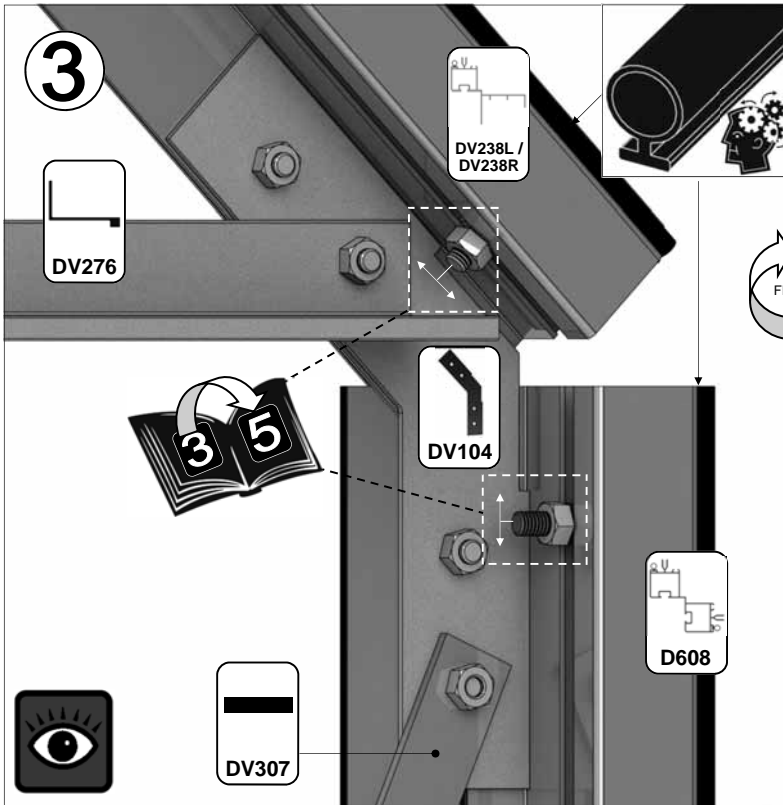
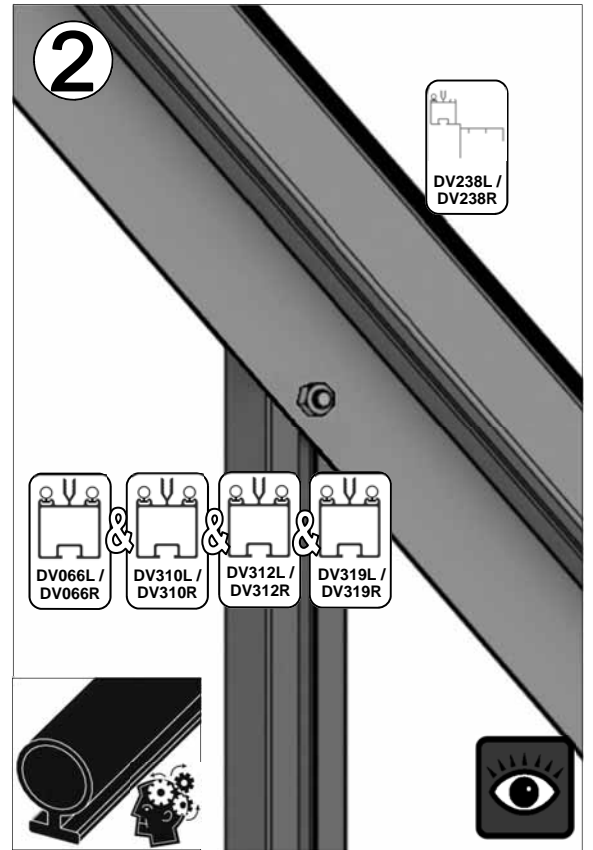
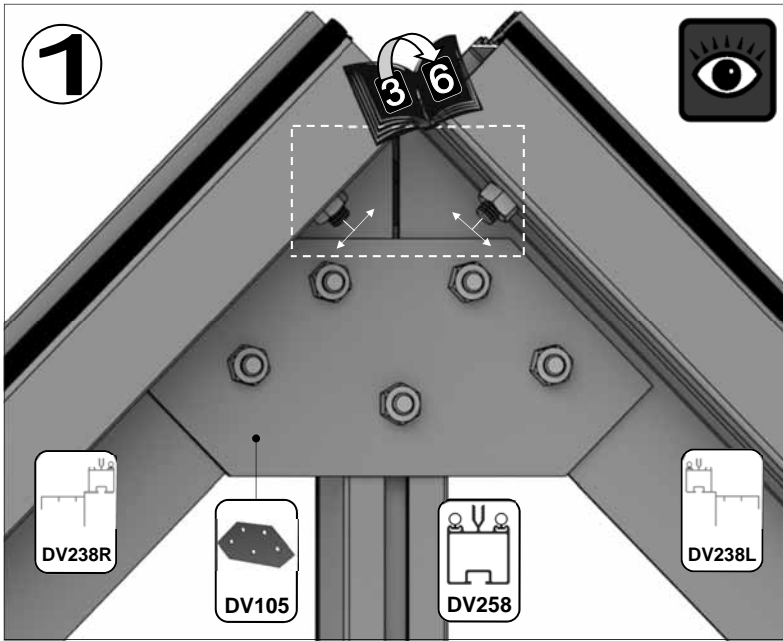

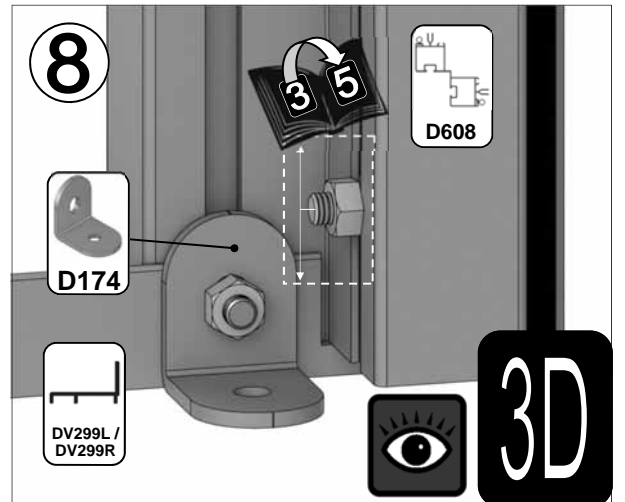
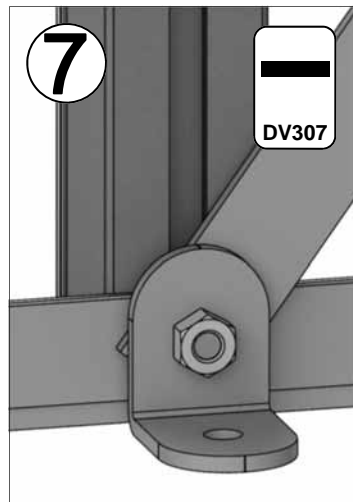
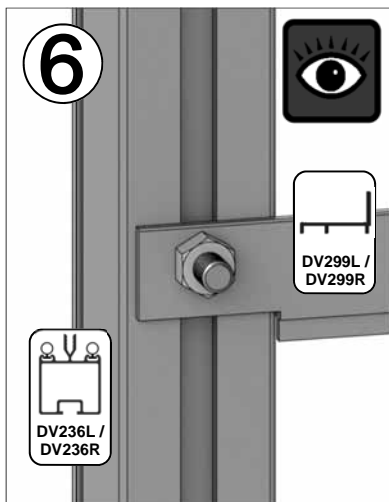
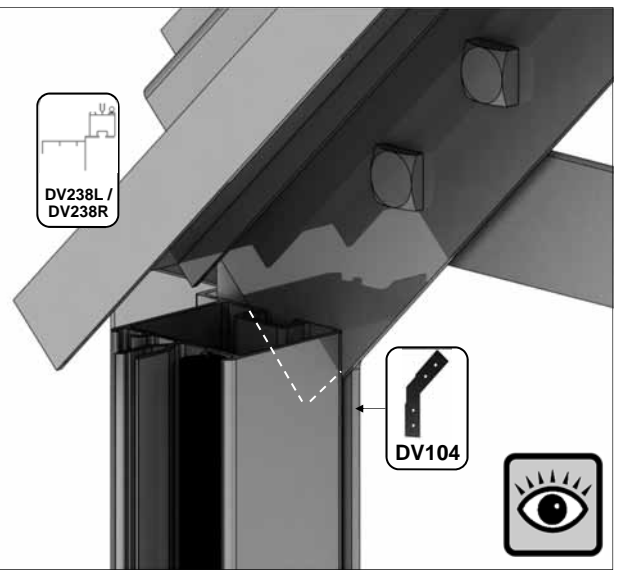
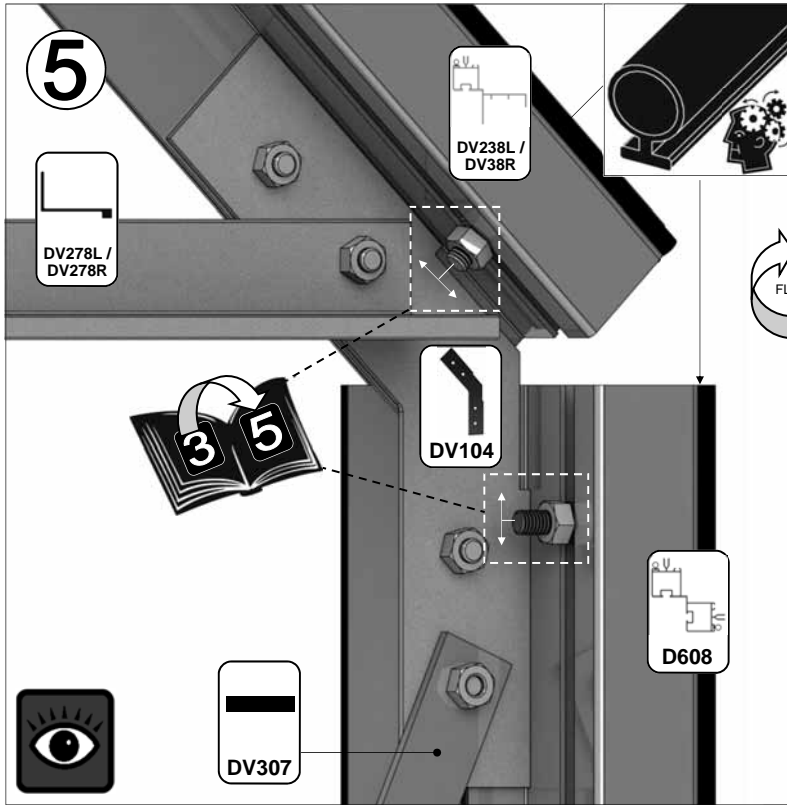
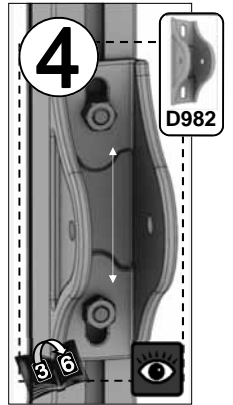
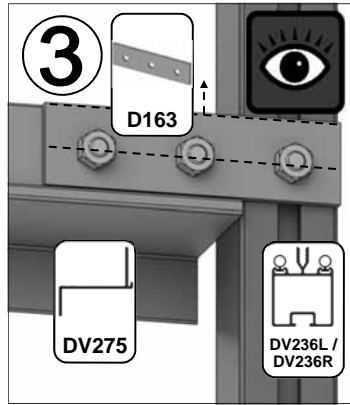
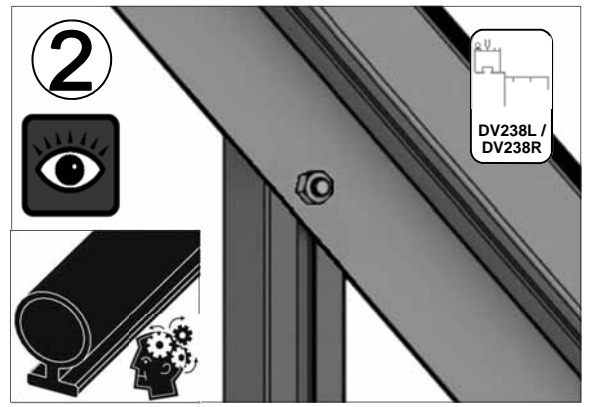
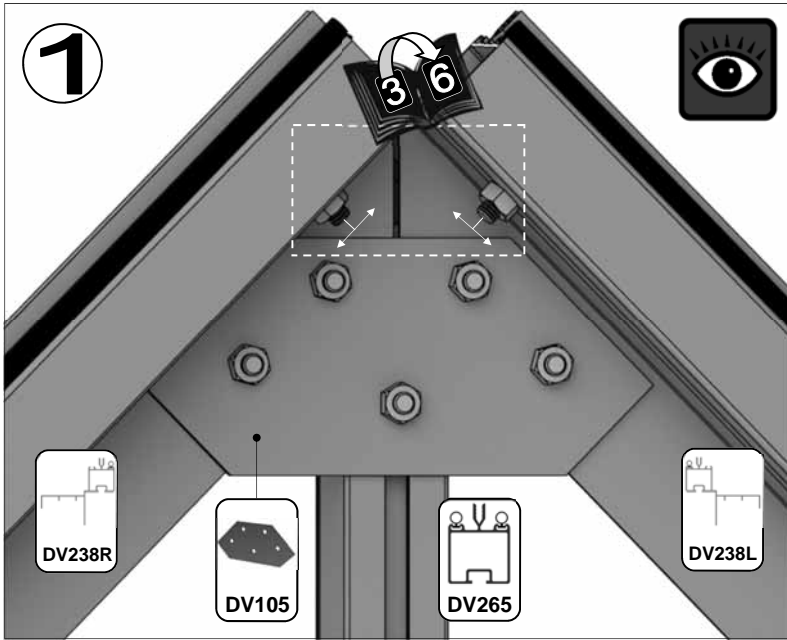

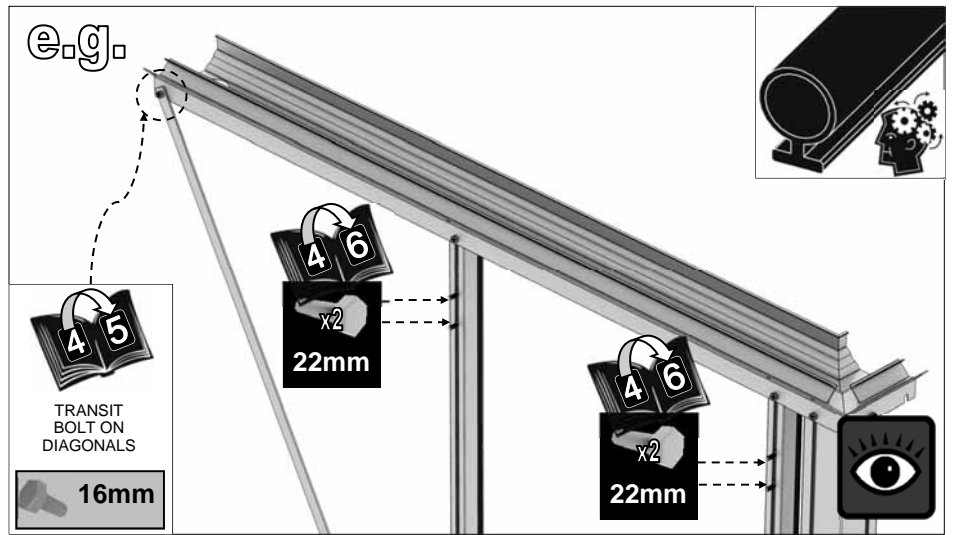
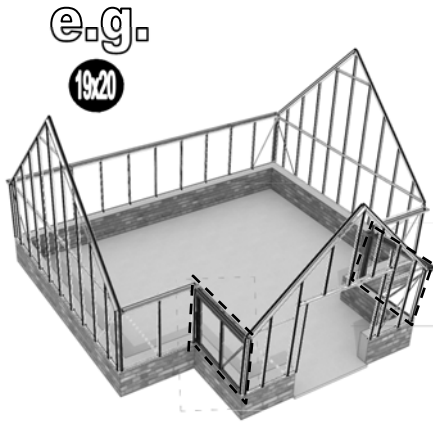

| PORCH SIDES | | 19x12 CORE |
|-----------------|--------|------------|
| Part No | mm | Quantity |
| D604 | 1316 | 2 |
| D609 | 1160 | 4 |
| DV363 | 1160 | 2 |
| DV558 | 143 | 1 |
| DV559 | 143 | 1 |
| DV574 | 1383 | 1 |
| DV575 | 1383 | 1 |
| DV578 | 165 | 1 |
| DV579 | x 1407 | 1 |
| D174 | | 6 |
| D227 Rubber | 1000 | 14m |
| FS6505 HEX 12mm | | 10 |
| FS6506 HEX 16mm | | 8 |
| FS6507 HEX22mm | | 8 |
| FS6504 M6 NUT | | 18 |

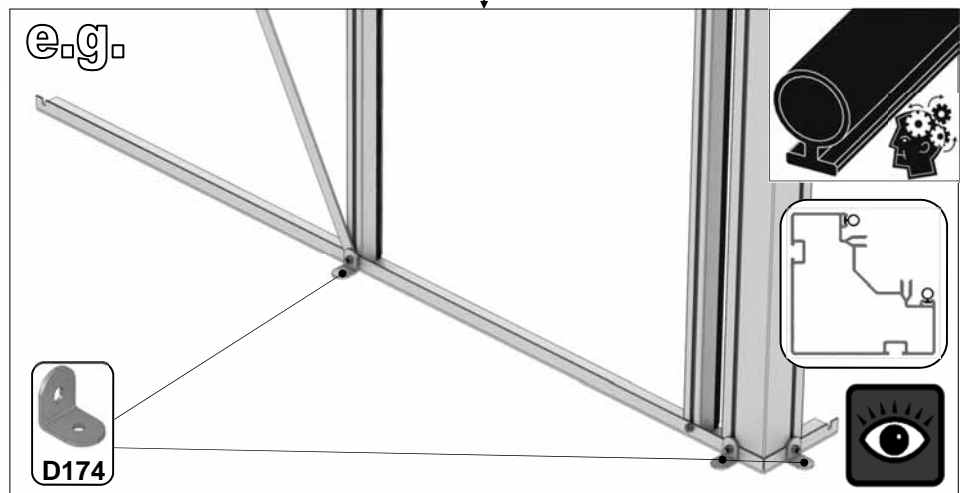
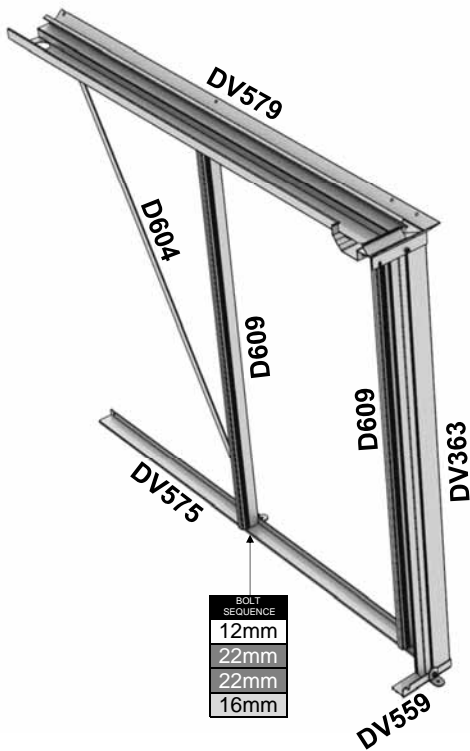
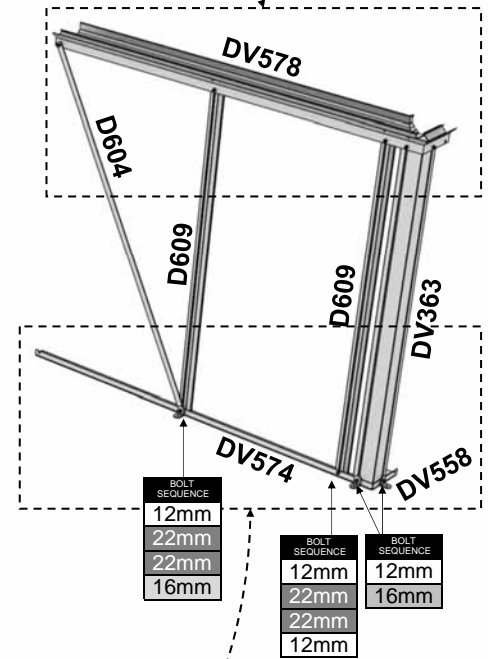

4

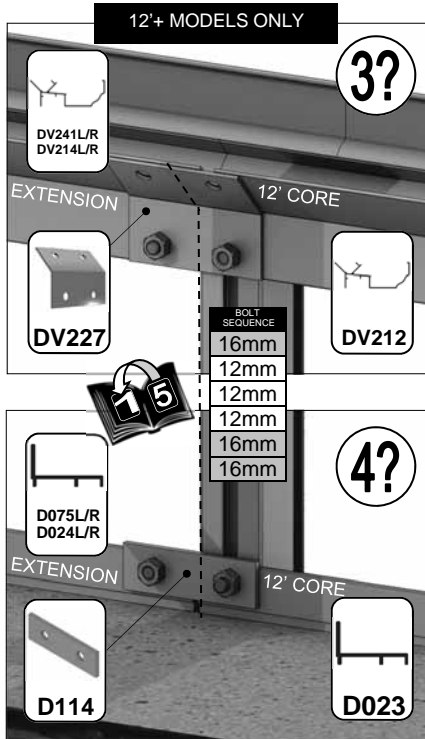
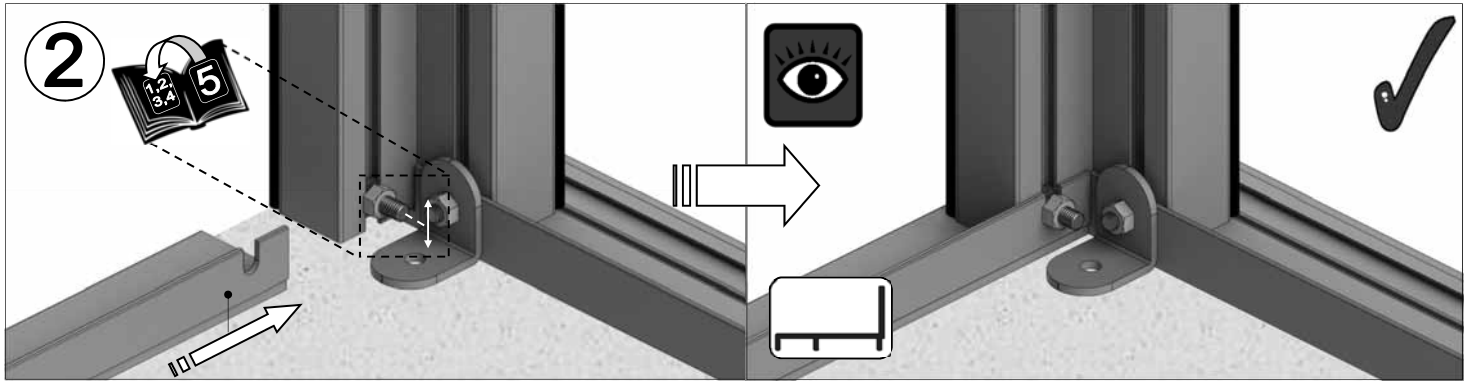
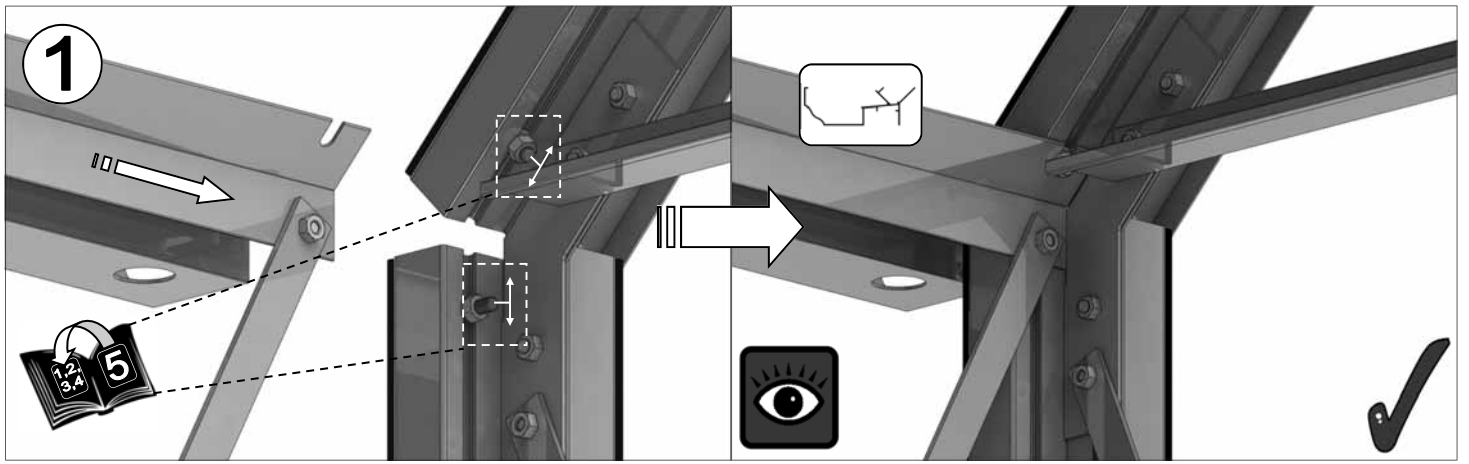





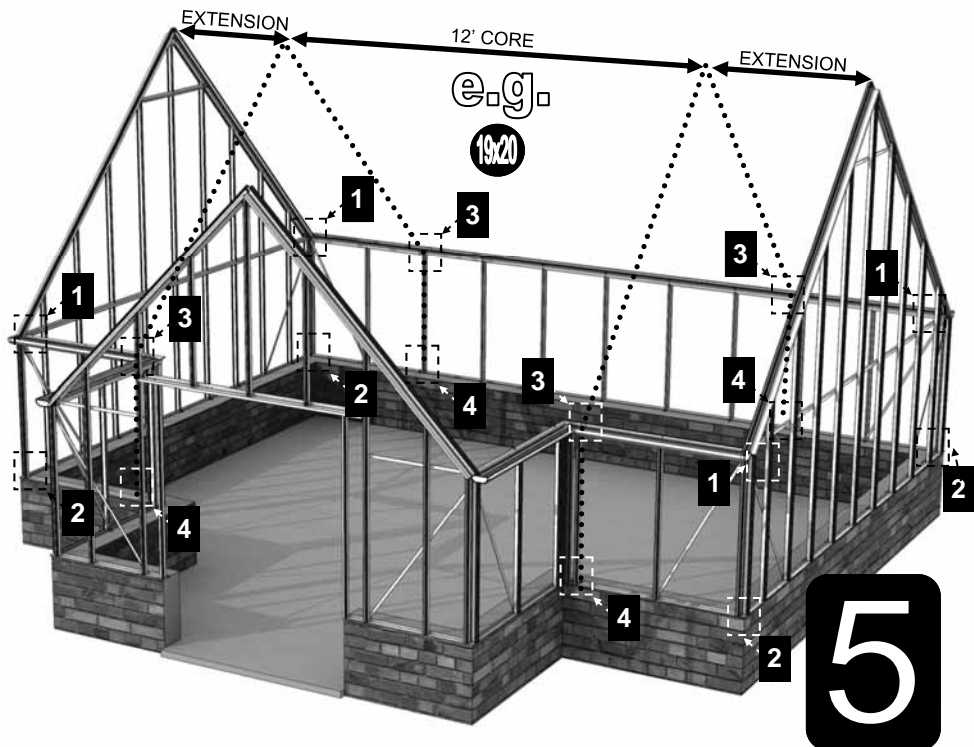
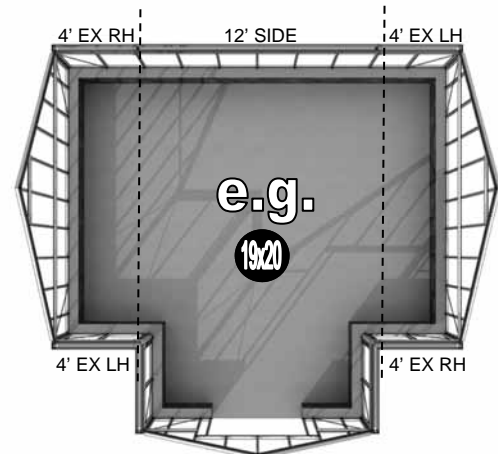

IMPORTANT FOR MODELS OVER 12':

If you have been supplied with an extension (i.e. your building is longer than 12'), your main building will differ in that the roof end and side corner glazing bars (on the end to which the extension will be fitted) are replaced with side and roof glazing bars from the extension module kit. These should be fitted using 16mm bolts, see left. In addition, it will be necessary to slide additional 12mm and 16mm bolts into each side bar to accommodate a reinforcing channel. The bottom two 16mm bolts will be used to fit the cast a-frame brackets 'D855' later in assembly.

When fitting the extension gutters and side cills, the 586mm hole centres at one end of the extension components must abut the main greenhouse 12' core. You will notice that unlike your common length / core (porched models) the; ridge, gutters and cills on extension components have holes at one end and the usual open U-shaped slots at the other. It is the end with the holes which must abut the core. At the extension joint the side and roof bars to which the a-frame is mounted need to go onto the U-shaped slots not the holes of the extension components. Each of the extension joining plates 'DV227' and 'D114' attach the main 12' core building onto the 586mm spaced hole end of each extension section. Each glazing bar centre should then be **620mm** apart, if not your glass will not fit properly.



| MAIN ROOF | | 19x12 | 19x20 | 19x28 |
|-----------------|--|----------|-------|-------|
| Part No | mm | Quantity | | |
| D114 | N/A | | | 4 |
| D137 | 2176 | | | 2 |
| DV597 | 1114 | | | 4 |
| D855 | N/A | | | 4 |
| D982 | 106 | | | 2 |
| DV203 | 3757 | | | 1 |
| DV206 | 2480 | | | 2 |
| DV240 | 1240 | | 2 | |
| DV277 | 3110 | 5 | 13 | 21 |
| DV279 | 3036 | | | 4 |
| DV297 | 2832 | | | 2 |
| DV298 | 1772 | | | 4 |
| DV365 | 882 | | | 2 |
| DV100 |  | 9 | 13 | 21 |
| DV101 |  | 2 | 4 | 8 |
| DV153 | N/A | | | 8 |
| D227 Rubber | 1000  | 32m | 81m | 131m |
| FS6505 HEX 12mm |  | 14 | 50 | 66 |
| FS6507 HEX 22mm |  | 24 | 40 | 72 |
| FS6006 HEX 35mm |  | 4 | 32 | |
| FS6504 M6 NUT |  | 42 | 122 | 170 |

The end gables and ridge of your greenhouse are supported by a 'DV101' 90 degree spandrel and a box brace 'D137' which needs to be mounted at a 45 degree angle between two 'D982' castings, see below.

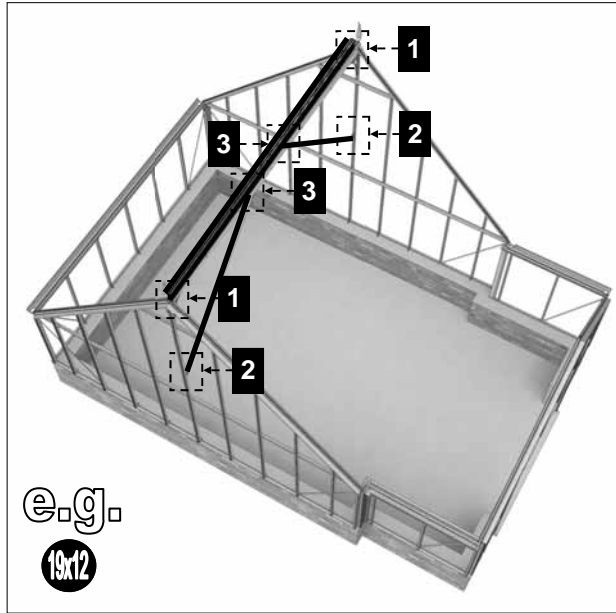

IMPORTANT:
Please slide the following sequence of 12mm and 22mm bolts (22,22,12,12,12,12,22,22) into the bolt slot in the bottom of the ridge prior to attaching it, e.g. 'DV203', sliding four towards each gable. On extended models the four bolts need to be slid into the outermost extension ridges. These bolts (2 x 12mm) allow each 'D982' casting to be mounted on the underside of the ridge and (2 x 22mm) for each 'DV101' spandrel to be added to stiffen the end gables.

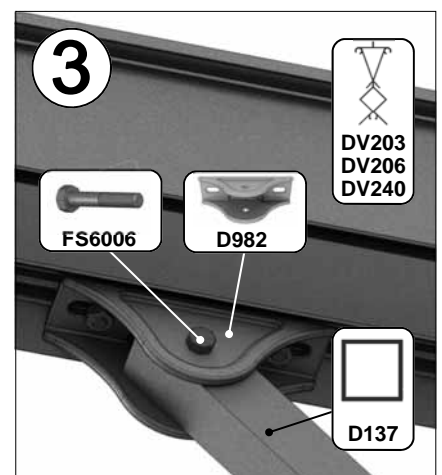
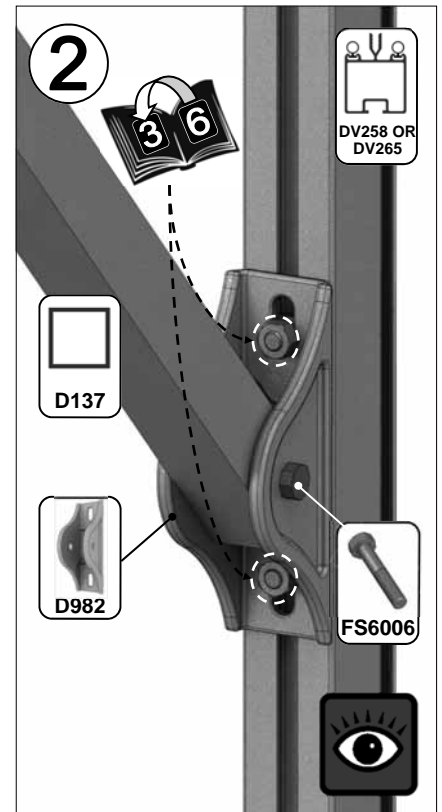
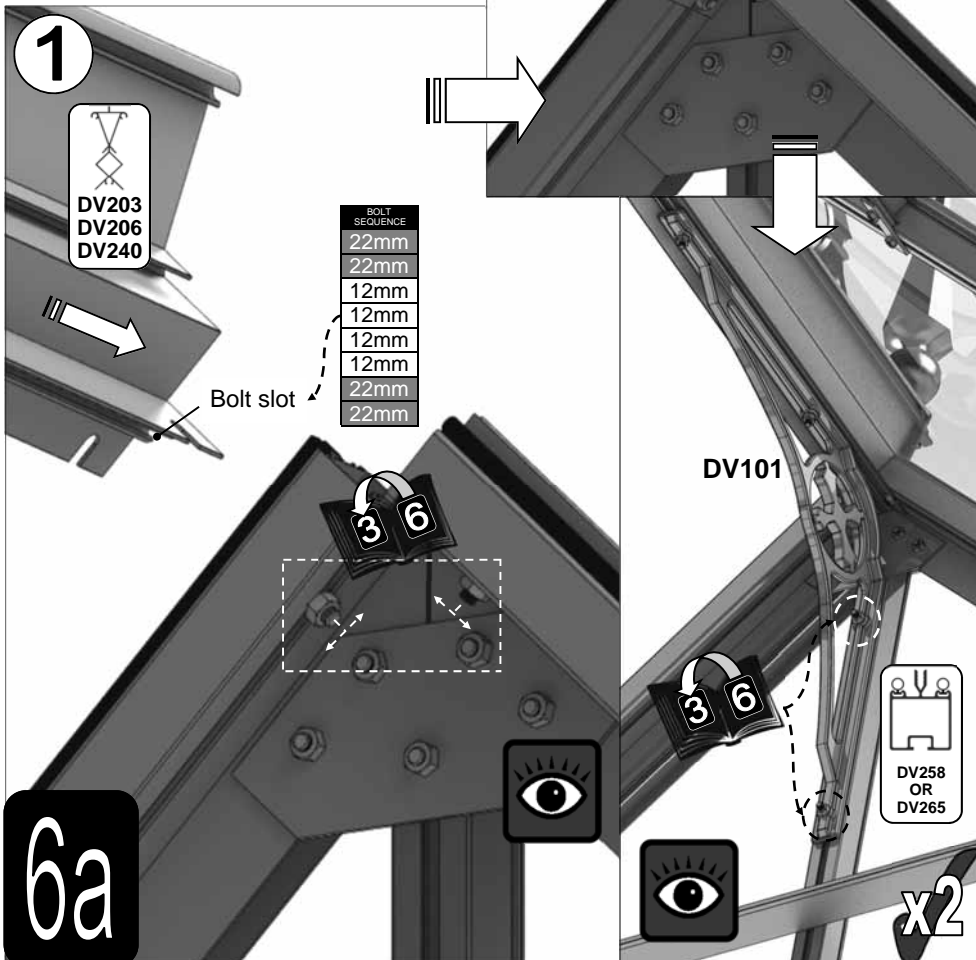

IMPORTANT:
 Please slide the following sequence of 12mm and 22mm bolts (12,22,22,12,22,22,12) into each DV277 roof bar to allow attachment and to enable the DV100 / DV101 spandrels and roof purlings to be installed.
 On 12' plus extended models where A-frames (see next page) are situated at the extension joint there are no spandrels, instead please slide 9 x 12mm bolts into each DV279 to allow for the DV279 A-frame roof channels to be fitted as well as for the attachment of the roof bars themselves.

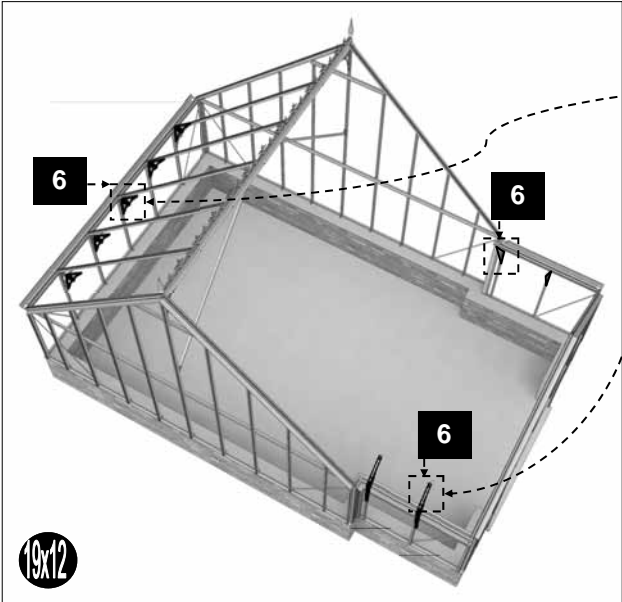
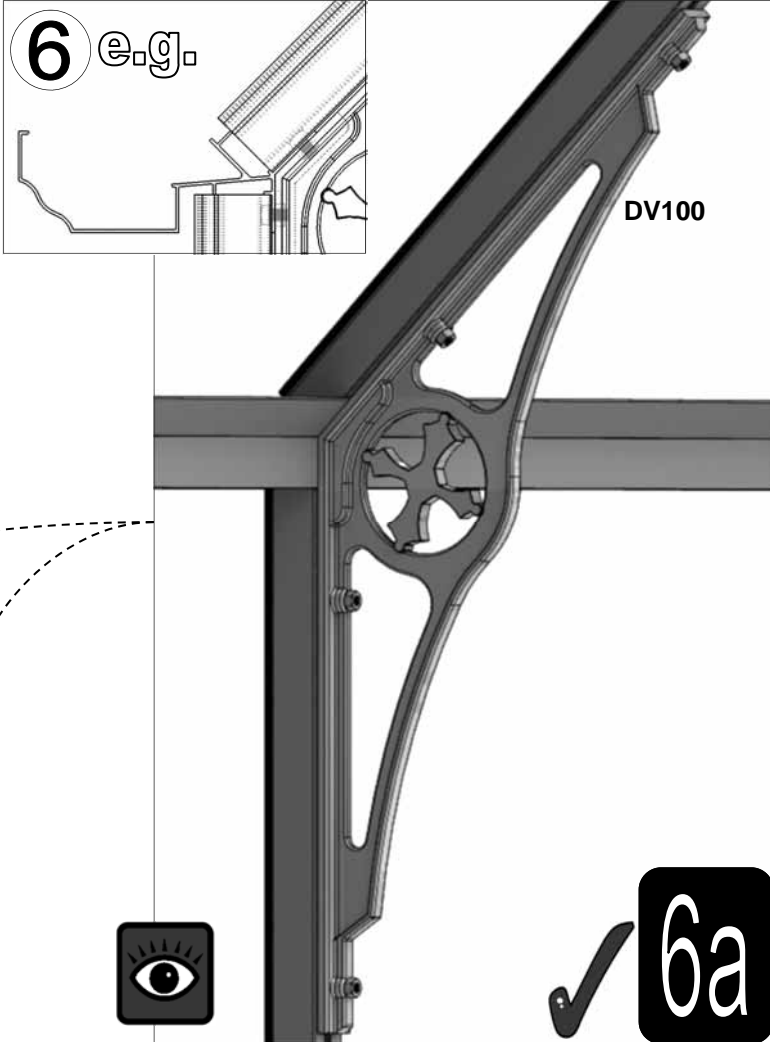
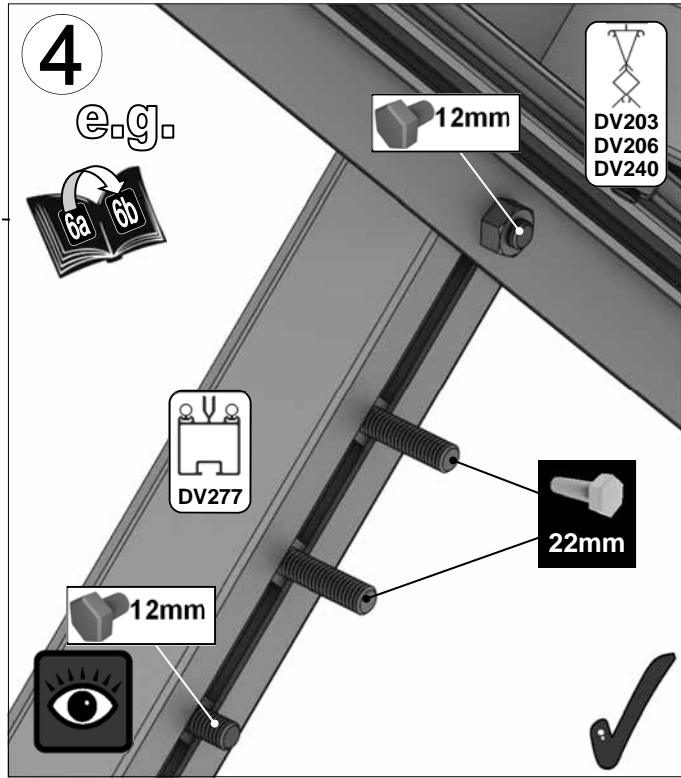
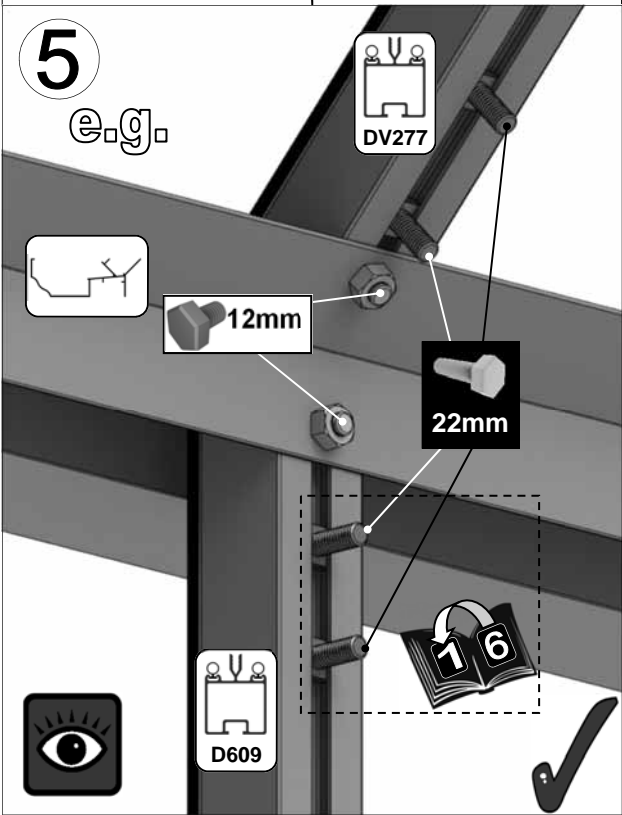
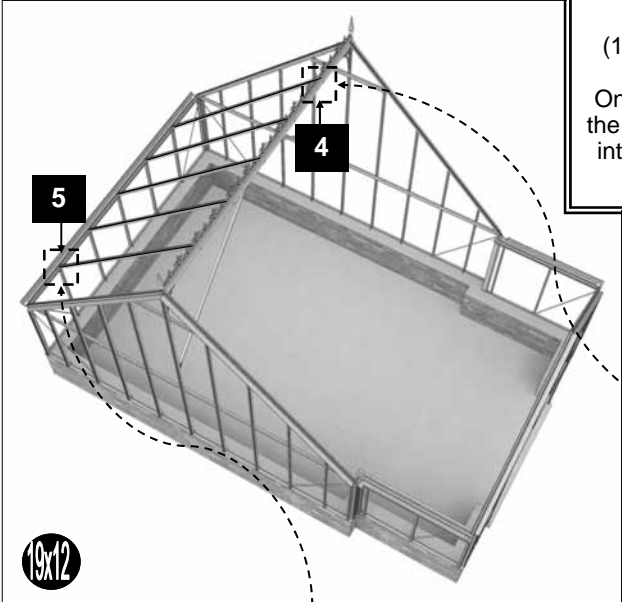

12+ MODELS ONLY

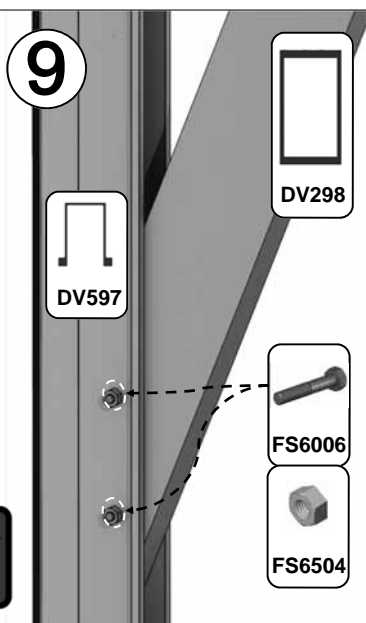
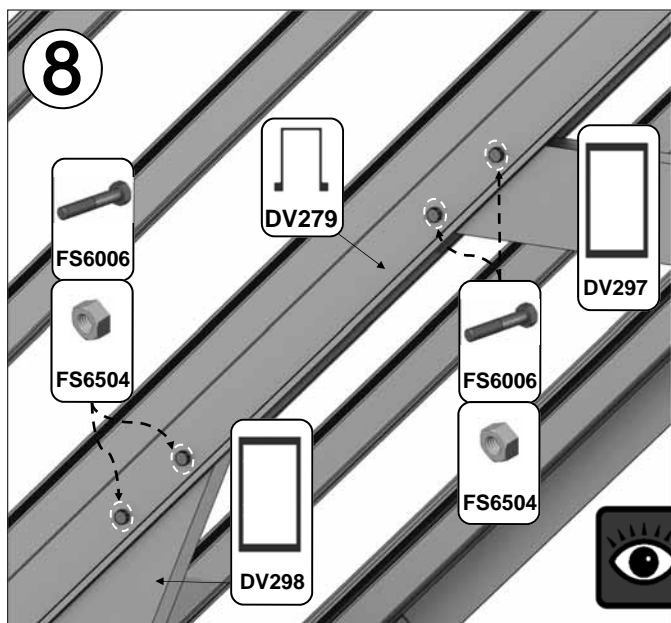
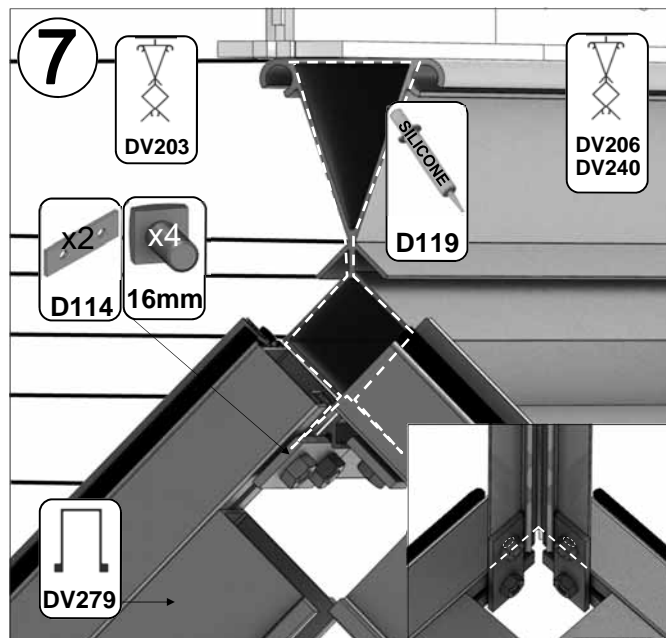
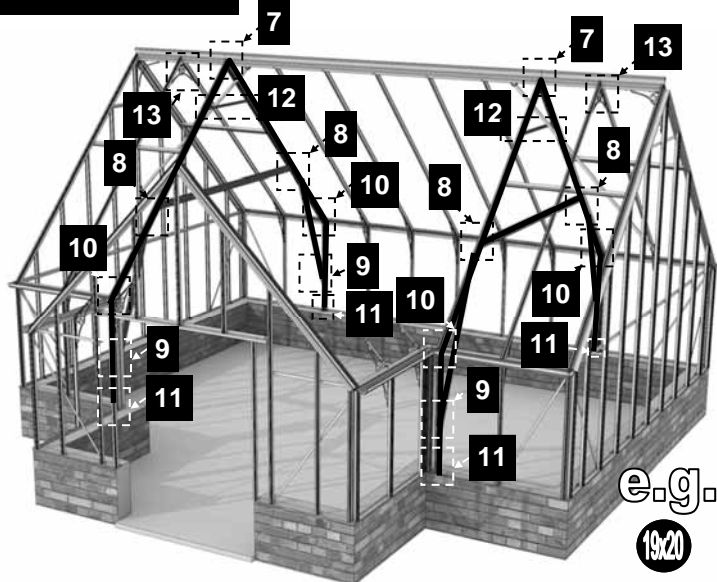

IMPORTANT: Extended buildings should have transparent all-weather silicone applied to the joint between a standard ridge and an extension ridge/s to minimise leaks. This is often easier to do before glazing as access is easier. It is also advisable to repeat the process at gutter level on the gutter rear flanges though the gutter water channel itself is best sealed towards the end of construction, see page 42.

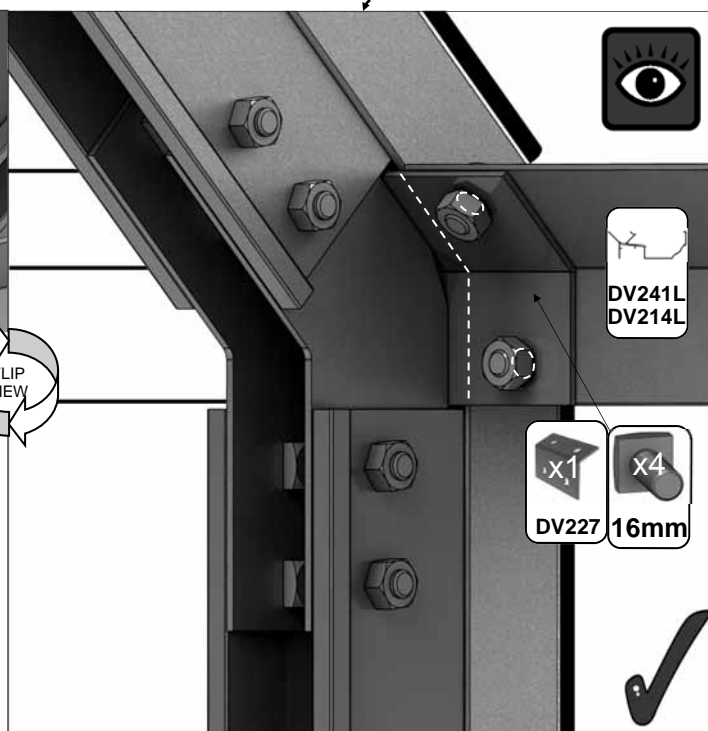
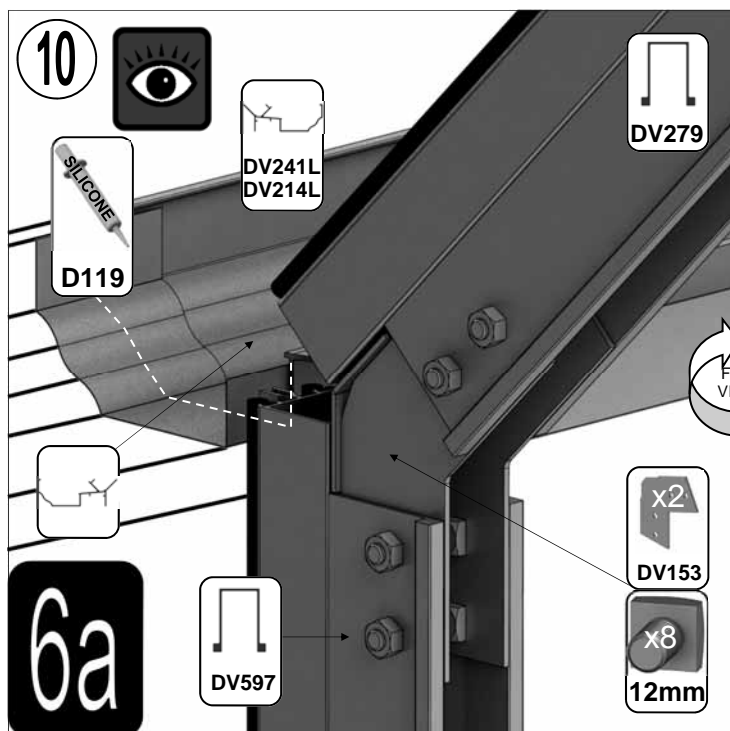

6a

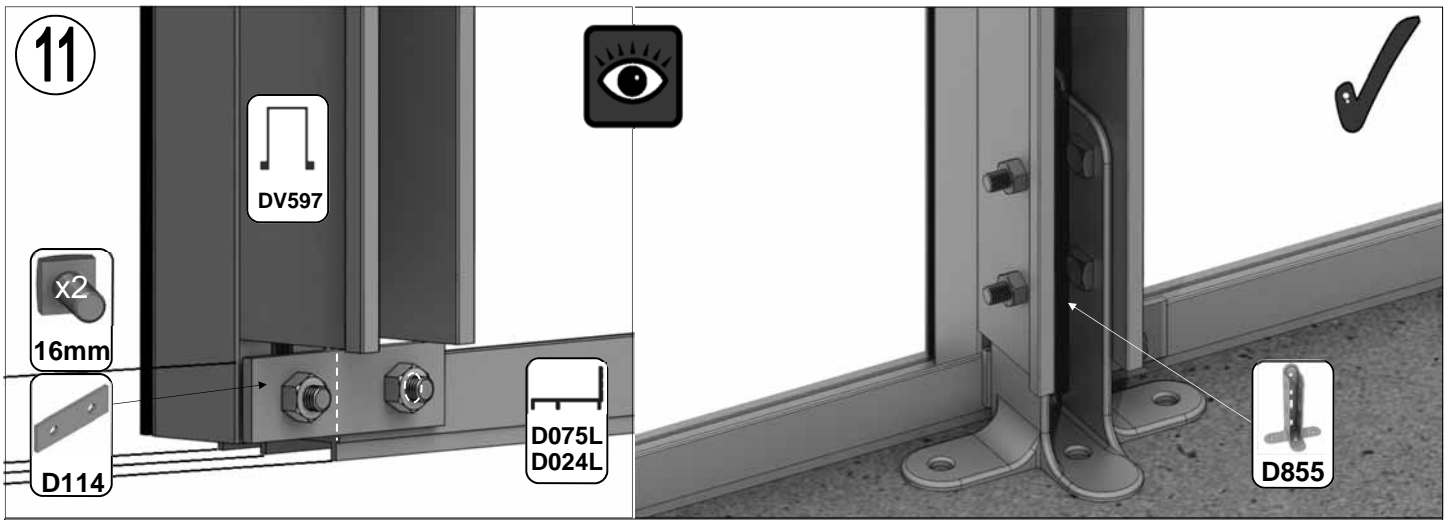

Once your extension cills have been joined using the D114 plates D855's then squeeze inside the a-frame channel and use existing bolts to secure themselves to the frame and well as new bolts in the channel sides. At the end of assembly the D855 brackets can be secured to the brickwork using 2" rawl plugs and screws having drilled 7mm diameter holes with a masonry bit, see page 40.

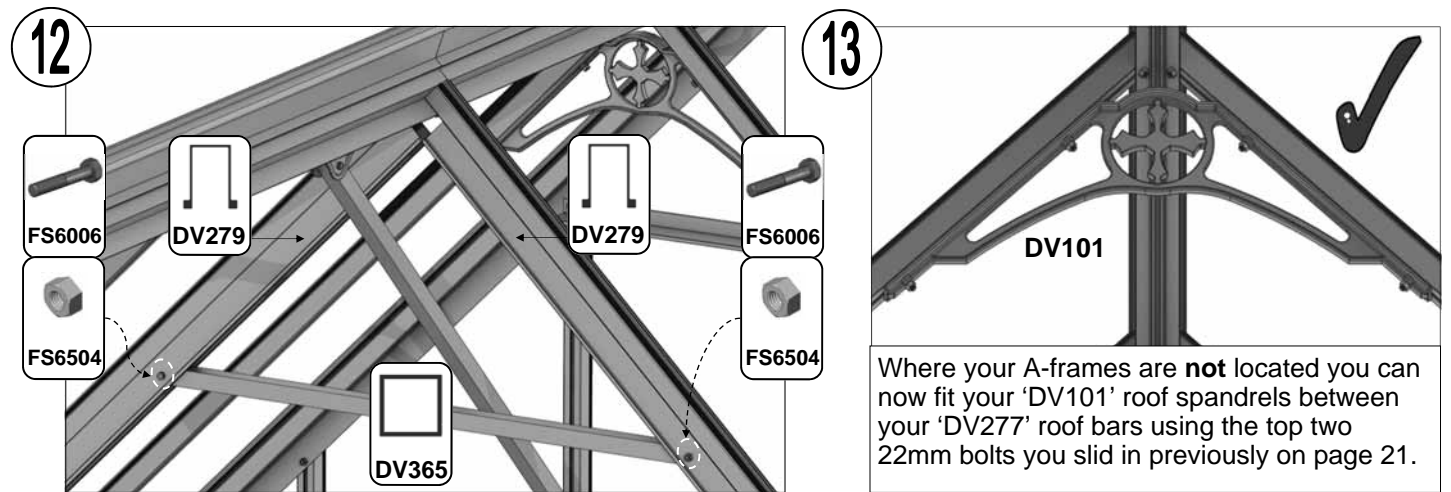



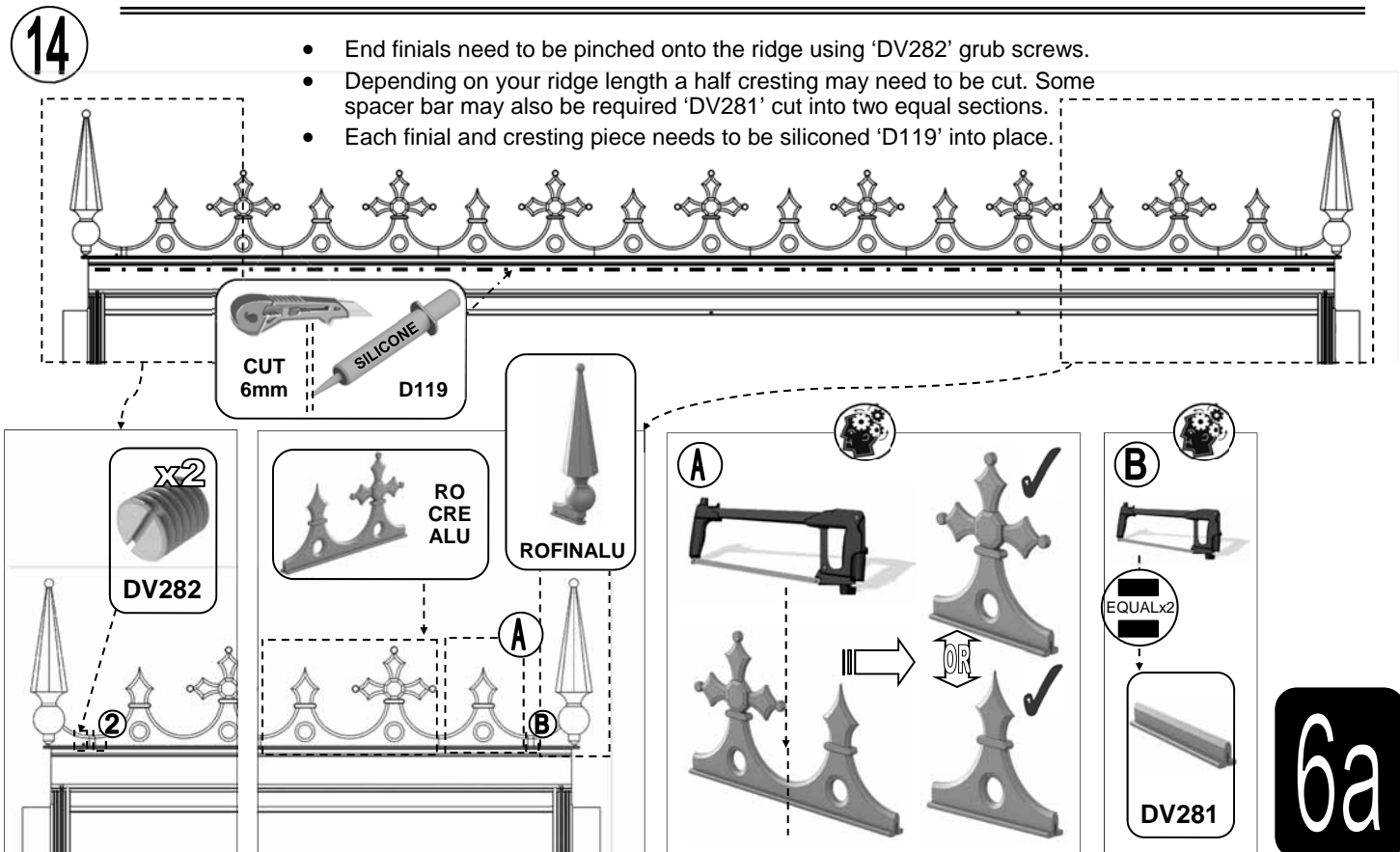



Where your A-frames are **not** located you can now fit your 'DV101' roof spandrels between your 'DV277' roof bars using the top two 22mm bolts you slid in previously on page 21.



- End finials need to be pinched onto the ridge using 'DV282' grub screws.
- Depending on your ridge length a half cresting may need to be cut. Some spacer bar may also be required 'DV281' cut into two equal sections.
- Each finial and cresting piece needs to be siliconed 'D119' into place.

6a

| PORCH ROOF | | 19x12 | 19x20 | 19x28 |
|-----------------|--|----------|-------|-------|
| Part No | mm | Quantity | | |
| D596 | 3757 | 2 | | |
| D598 | 2480 | | | 4 |
| D599 | 1240 | | 4 | |
| D982 | 106 | 2 | | |
| DV101 | n/a | 10 | | |
| DV255 | 2450 | 4 | | |
| DV352 | 3090 | 1 | | |
| DV365 | 882 | 1 | | |
| DV375L/R | 830 | 1 + 1 | | |
| DV376L/R | 1708 | 1 + 1 | | |
| DV377L/R | 1492 | 1 + 1 | | |
| DV378L/R | 2368 | 1 + 1 | | |
| DV380 | n/a | 1 | | |
| DV383 | 661 | 1 | | |
| DV570 | 3018 | 2 | | |
| D174 |  | | 4 | |
| D227 Rubber | 1000  | 47m | | |
| FS6505 HEX 12mm |  | 64 | | |
| HE569 CROP BOLT |  | 4 | 8 | 16 |
| FS6507 HEX 22mm |  | 36 | | |
| FS6504 M6 NUT |  | 104 | 108 | 116 |

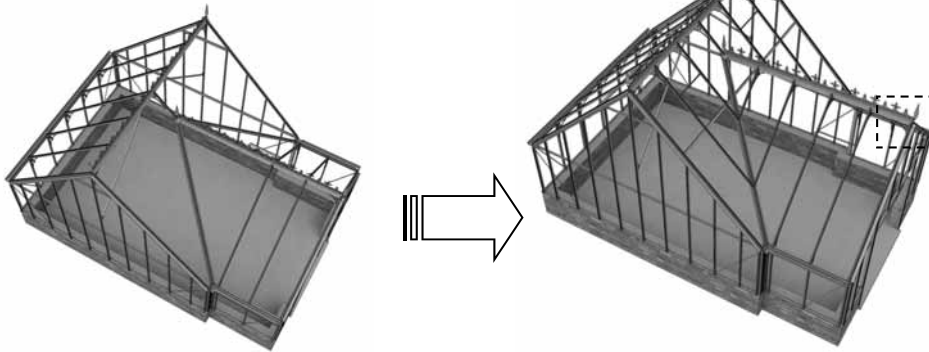
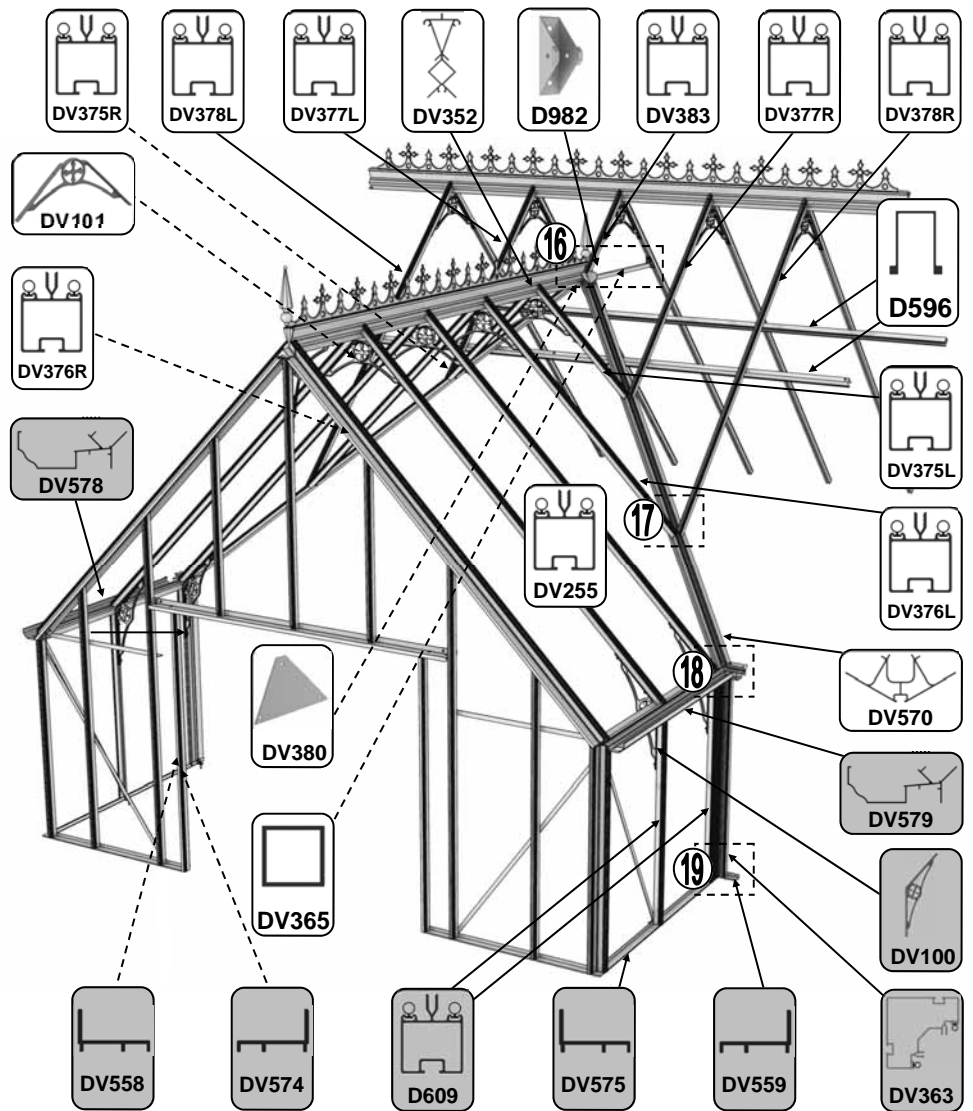

IMPORTANT:
Please slide two 22mm bolts into the bolt slot in the underside of your ridge DV352 to allow for a DV101 90 degree spandrel to be attached to support the porch door gable.

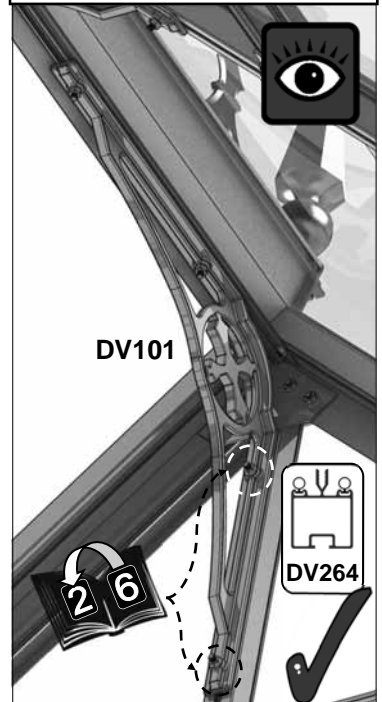

15 Lateral purlins e.g. 'D596' are fitted into the roof on the Rufford model. They add strength and stop the roof bars from splaying apart. Use the top 12mm bolt previously slid into each 'DV277' long roof bar (page 21) to attach them and use twist-in crop headed bolts on your porch main body roof bars, e.g.'DV377R'. We recommend siting them 1825mm up from the top edge of the gutter top flange where they will hide the lower glass overlap in the roof, see right. Because of the a-frames used on extended (12'+ long) some of your purlins will need to be shortened in length to fit. L-shaped 'D174' brackets should be used to mount the ends onto the roof a-frame channels 'DV279'. Holes will need to be drilled into shortened purlins and into the side of 'DV279's'.

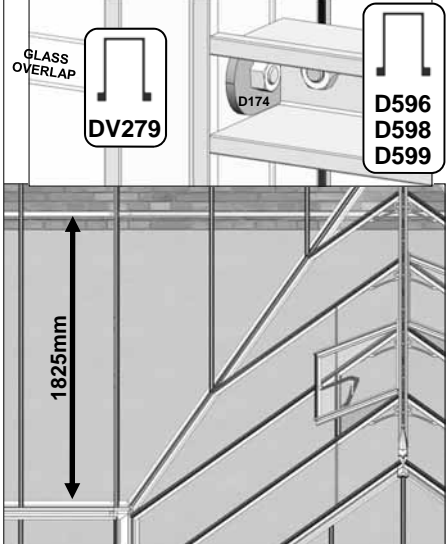

6b

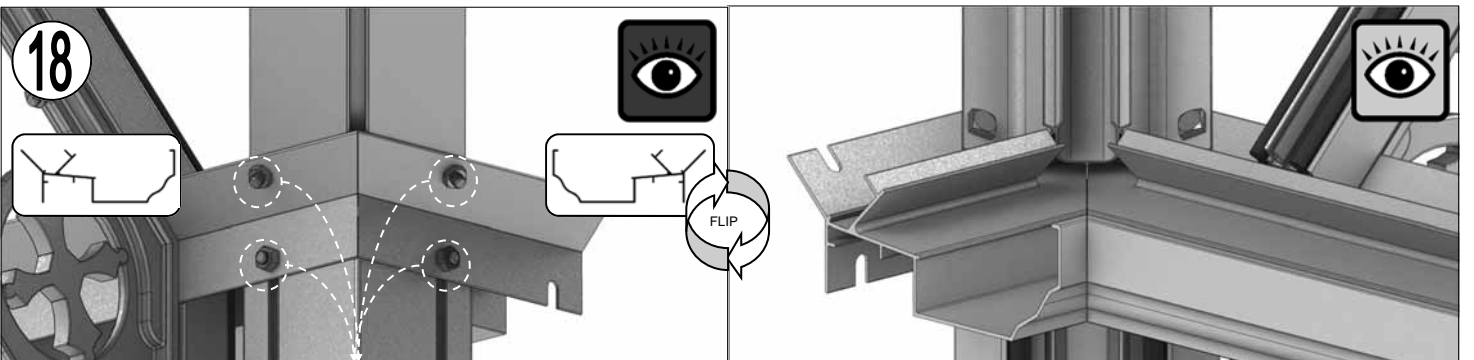
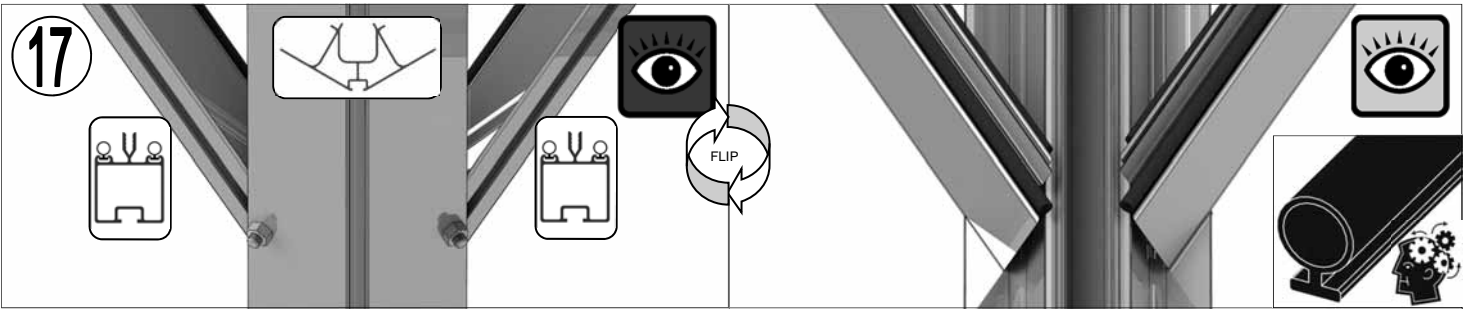
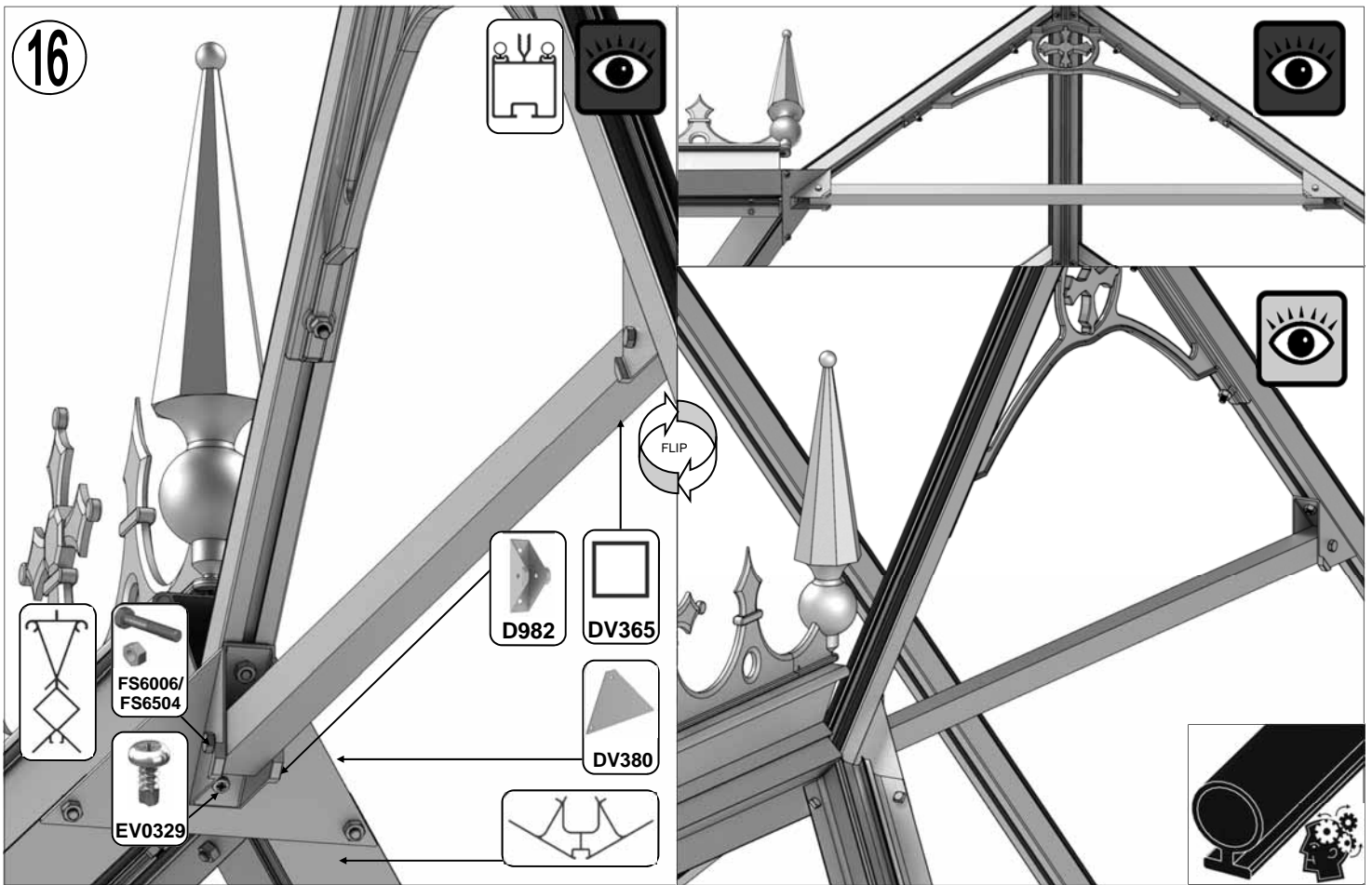

IMPORTANT: Because your porch gutter sections are welded together to eliminate the chance of any leaks the holes circled above can vary slightly in their locations. They may therefore require slight alteration to marry up with DV363 and DV570. Using an 8mm drill bit to enlarge the standard 7mm holes will for example give a little more play to aid fitting.

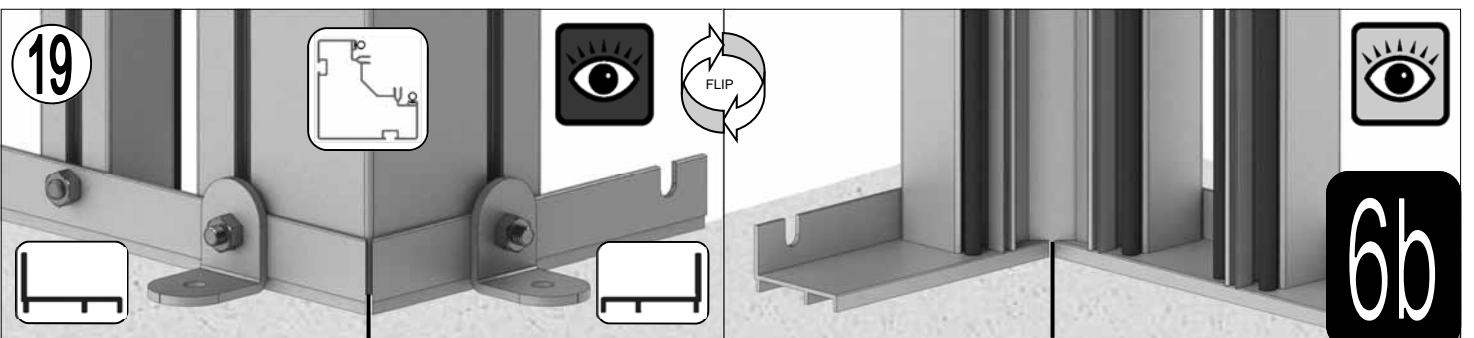



| Part No | | mm | Quantity |
|---------|--|-----|----------|
| D866 | | 639 | 1 |
| D863L | | 613 | 1 |
| D863R | | 613 | 1 |
| D862 | | 593 | 1 |

| Part No | | mm | Quantity |
|-------------------|--|-----|----------|
| D220 PLUS SCREW | | N/A | 2 |
| D205 | | N/A | 2 |
| FS6505 HEX 12mm | | 12 | 4 |
| FS6504 M6 NUT | | M6 | 4 |
| 8 X 12 S/T FS6017 | | 10 | 2 |
| 8 x 19 S/T FS6018 | | 19 | 2 |

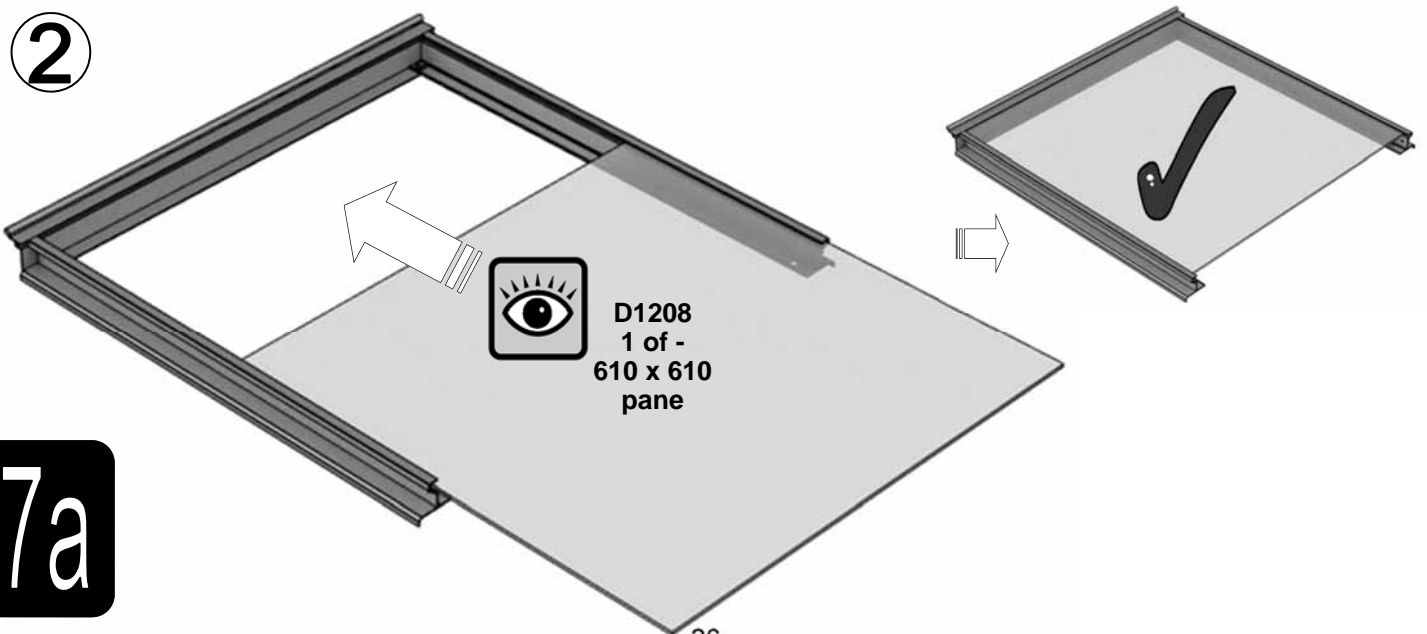
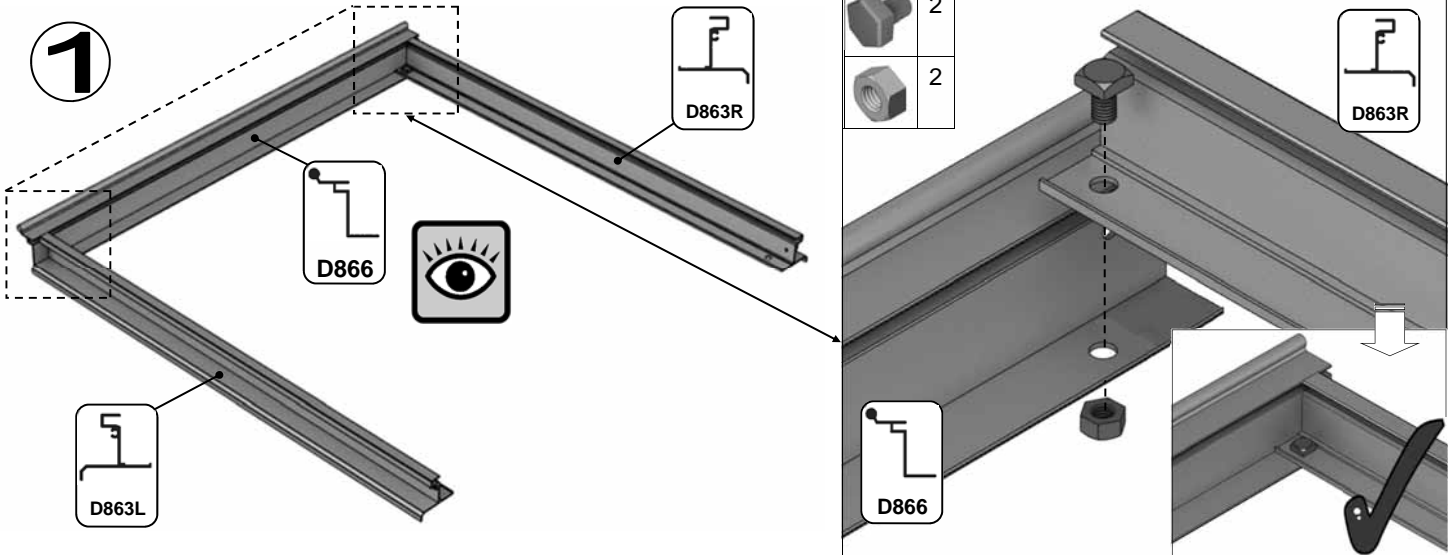

7a

3 

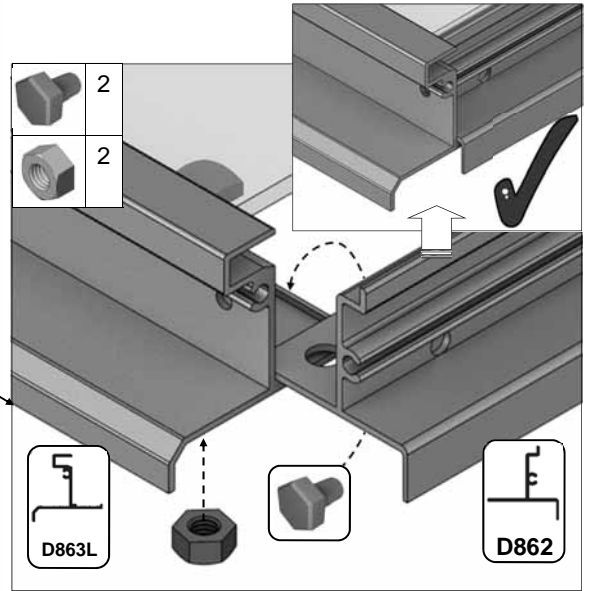
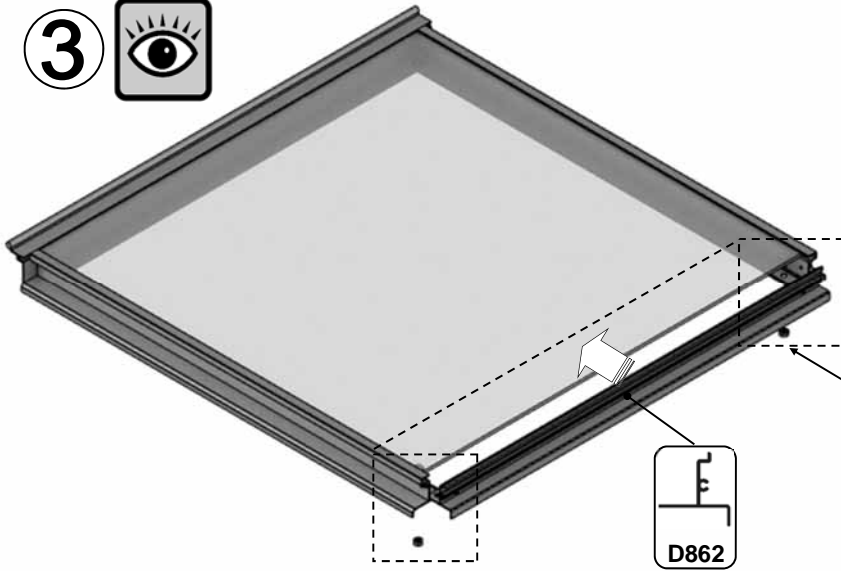

4 

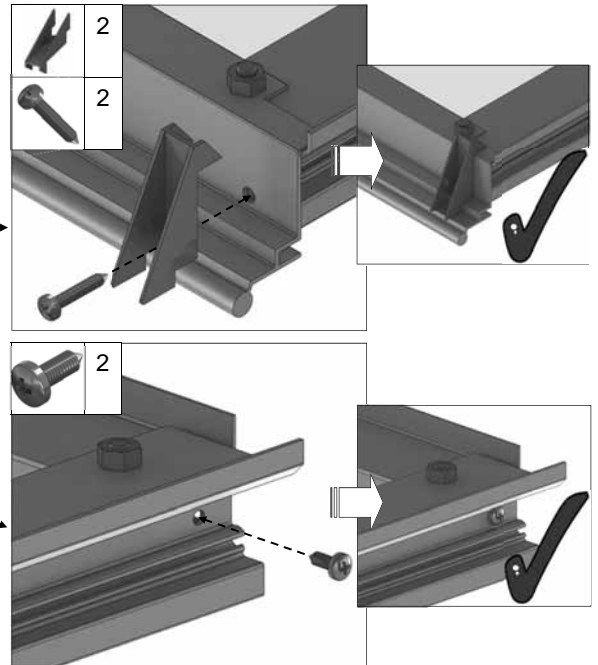
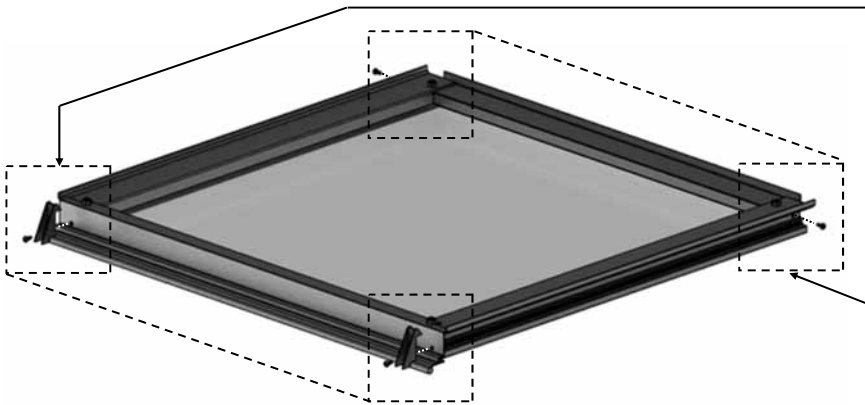
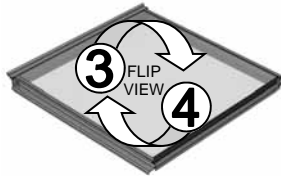



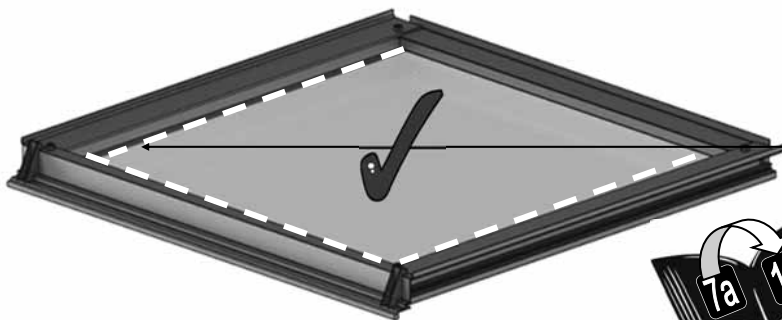

5 



7a

1 vent slam bar = {

6

| Part No | | mm | Quantity |
|-----------------------|---|-----|----------|
| FS6505 HEX 12mm |  | 12 | 4 |
| HE569 CROP BOLT |  | 10 | 2 |
| FS6504 M6 NUT |  | N/A | 4 |
| D079 PLUS FLUFF |  | 590 | 1 |
| D114 |  | N/A | 2 |

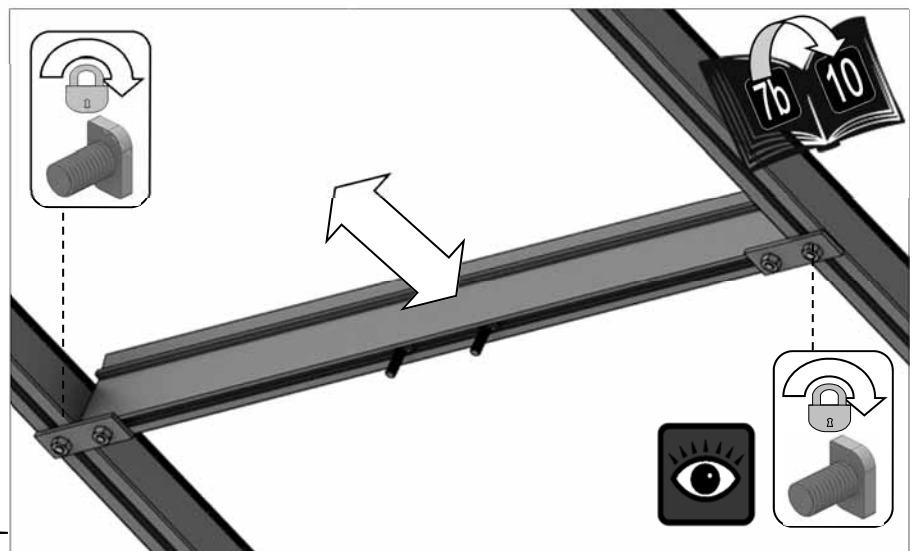
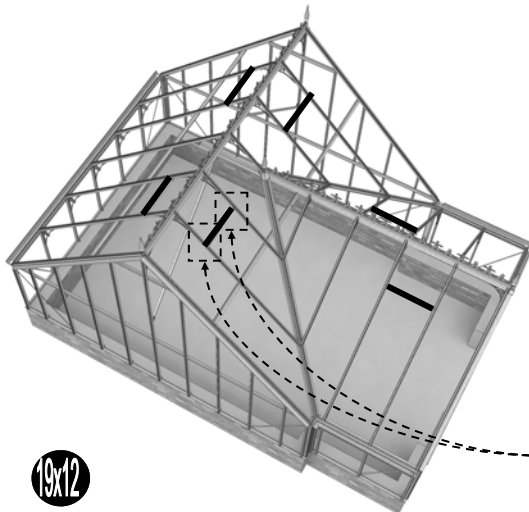
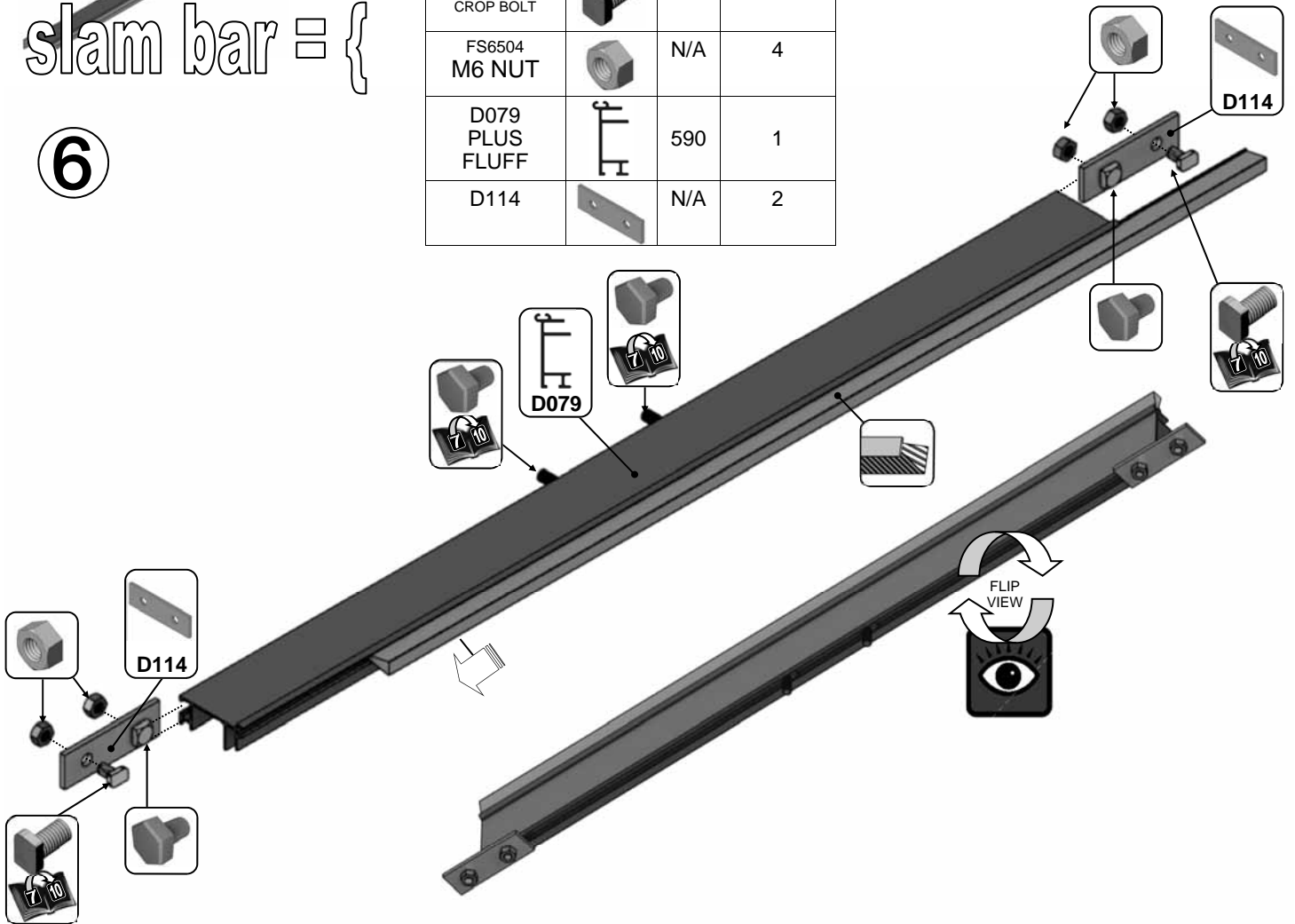

7b

A 'D079' slam bar can be attached to an A-frame using some of the spare base brackets 'D174'. Mark and drill into the roof reinforcing channels, see right. The height of the D079 being determined by the under vent panes.

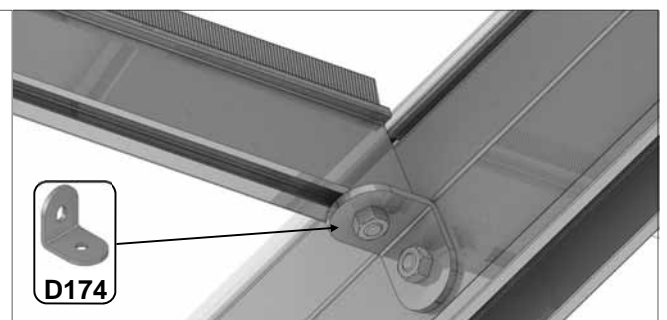

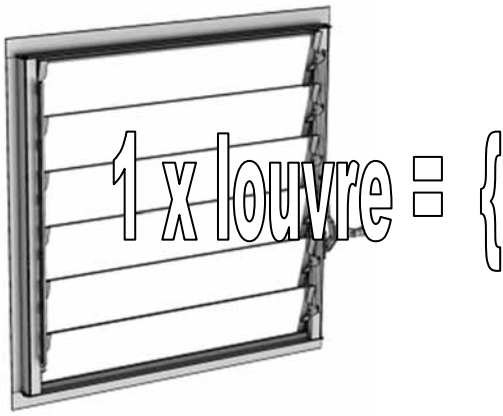

| Part No | | mm | Quantity |
|----------------|--|-----|----------|
| D168L | | 552 | 1 |
| D168R (handle) | | 552 | 1 |
| D165 | | 612 | 2 |
| D166 | | 552 | 2 |
| FS6013 | | 12 | 4 |

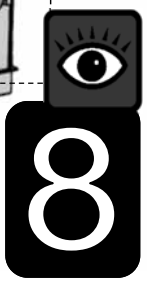
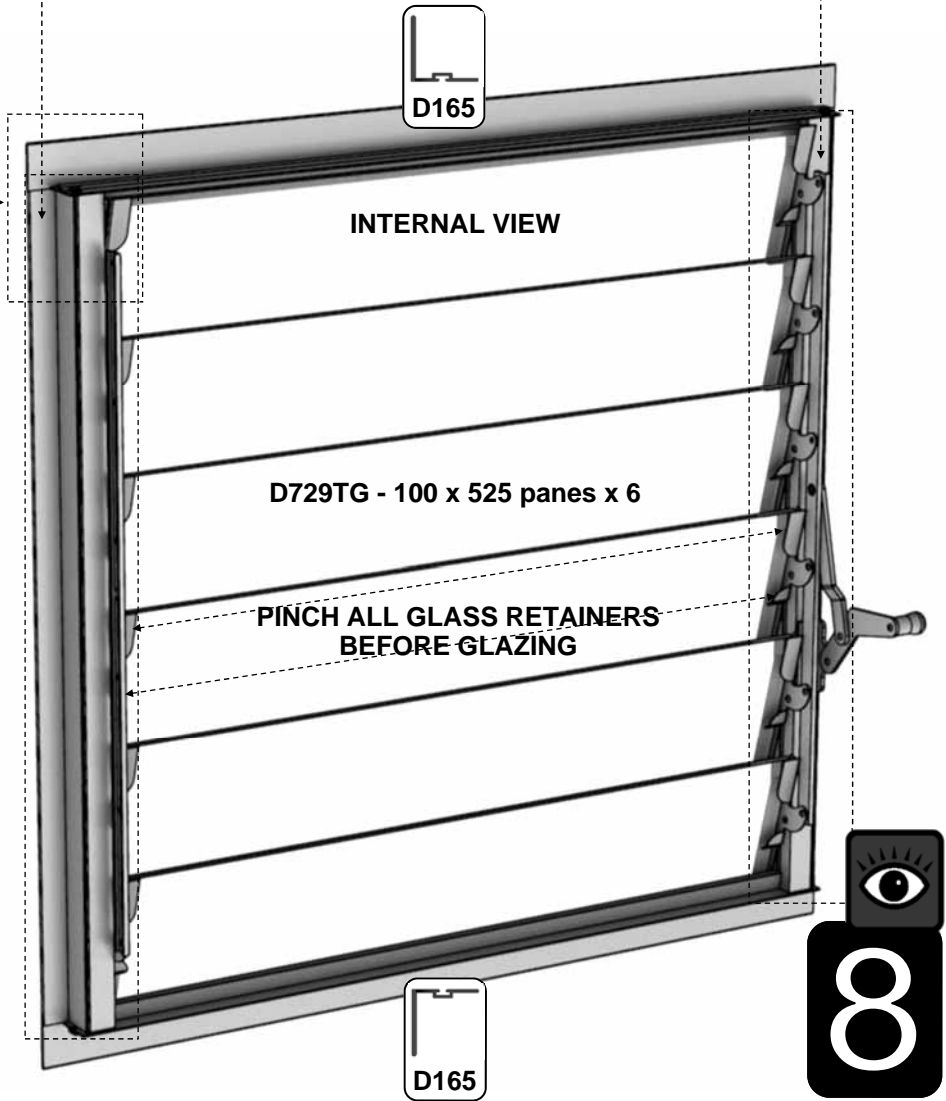
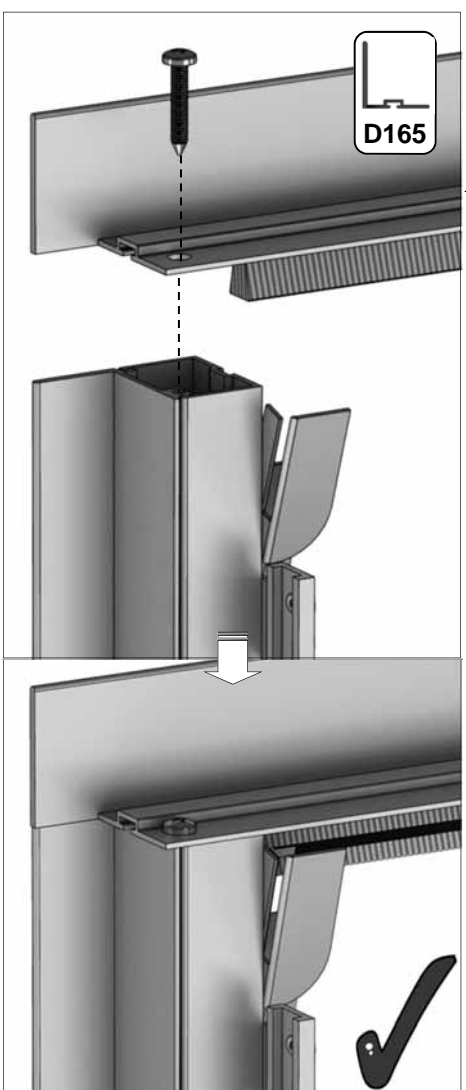
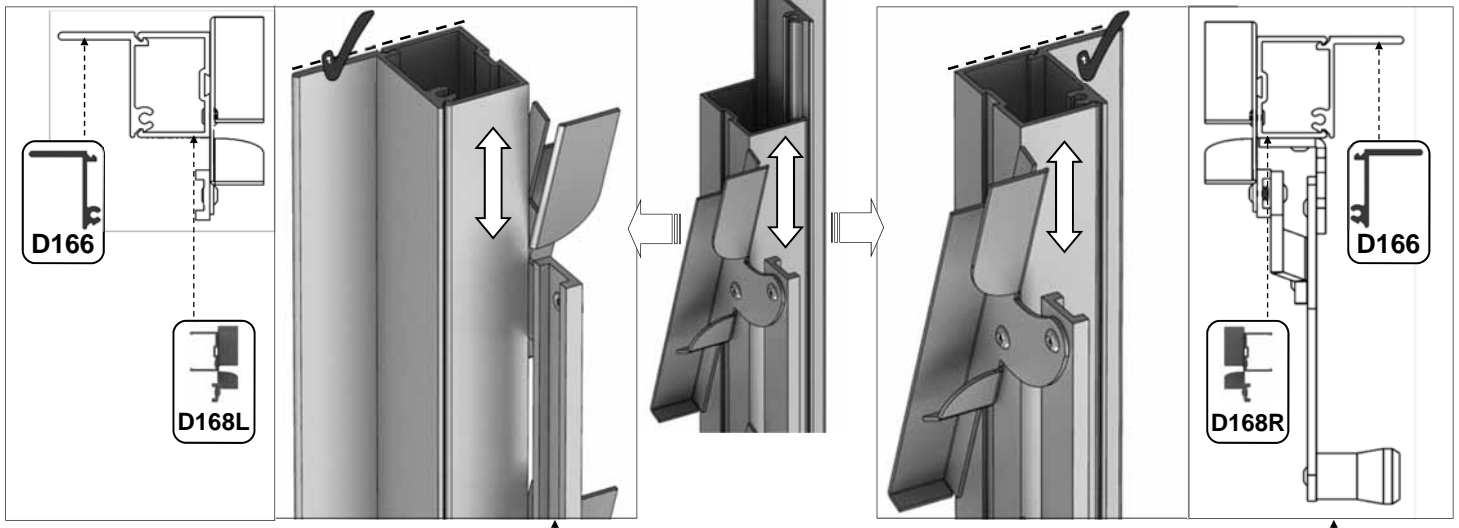

| PORCH CAPS AND COVERS | | | | 19x12 | 19x20 | 19x28 |
|-----------------------|---------|----------|----------|-------|-------|-------|
| PART No | SECTION | SIZE(mm) | QUANTITY | | | |
| D618 | | 1144 | 13 | 17 | 21 | |
| D870 | | 601 | 13 | 21 | 29 | |
| D883 | | 662 | 7 | 15 | 23 | |
| DV403L/R | | 1505 | 3 + 3 | | | |
| DV583L/R | | 921 | 1 + 1 | | | |
| DV595 | | 1470 | 2 | | | |
| DV610L/R | | 1972 | 3 + 3 | | | |
| DV612L/R | | 2438 | 2 + 2 | | | |
| DV616L/R | | 2905 | 2 + 2 | | | |
| DV641 | | 3342 | 2 | | | |
| DV655 | | 1880 | 9 | 17 | 25 | |
| DV664 | | 1373 | 1 | | | |
| DV675L/R | | 863 | 1 + 1 | | | |
| DV676L/R | | 1741 | 1 + 1 | | | |
| DV677L/R | | 924 | 1 + 1 | | | |
| DV678L/R | 1799 | 1 + 1 | | | | |
| DV683 | 680 | 1 | | | | |
| D610 | | 1160 | 6 | | | |
| D620 | | 1144 | 6 | | | |
| D871 | | 601 | 6 | | | |
| DV630 | | 660 | 4 | | | |
| DV652 | | 1871 | 6 | | | |
| D614 | | 1162 | 6 | | | |
| D619 | | 1144 | 19 | 23 | 27 | |
| DV584L/R | | 921 | 1 + 1 | | | |
| DV596 | | 1470 | 2 | | | |
| DV611L/R | | 1972 | 3 + 3 | | | |
| DV613L/R | | 2438 | 2 + 2 | | | |
| DV615L/R | | 1505 | 3 + 3 | | | |
| DV617L/R | | 2905 | 2 + 2 | | | |
| DV632 | | 3144 | 9 | 17 | 25 | |
| DV642 | | 3342 | 2 | | | |
| DV658 | | 2481 | 6 | | | |
| DV670 | | 1373 | 1 | | | |
| DV679L/R | | 863 | 1+1 | | | |
| DV680L/R | | 1741 | 1+1 | | | |
| DV681L/R | | 1525 | 1+1 | | | |
| DV682L/R | 2400 | 1+1 | | | | |
| DV684 | 680 | 1 | | | | |

GLAZING (plans pto):

Glass and aluminium can potentially cause injury. Please ensure you wear protective goggles, gloves, headgear and suitable footwear when assembling and glazing the building.



Please remember that glass is fragile and should be handled with extreme care. Always clear up and dispose of any breakages immediately.

Layout the plastic bar cappings e.g. D618 and covers e.g. D619 around the building like a sundial checking that all is present and correct. You can also place the roof cappings in the gutters so they are closer to hand.

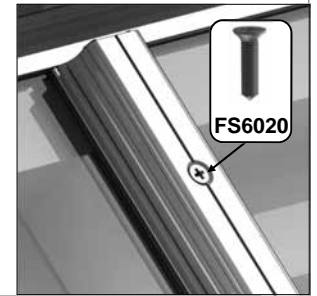

If you have a building which has aluminium cover caps then the roof covers are held in place with low-profile countersunk screws 'FS6020'. It looks neatest if all of these screws go towards the ridges of the building, see right.

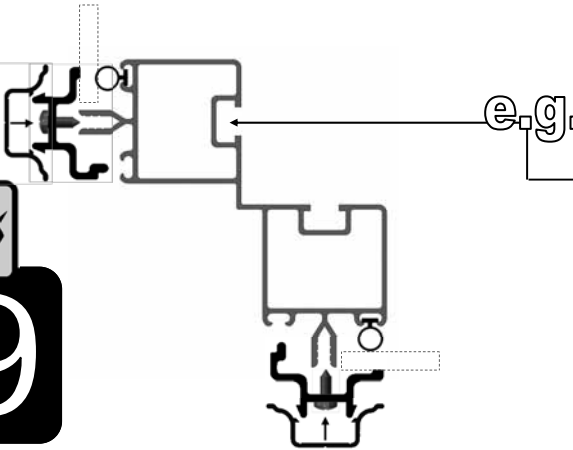
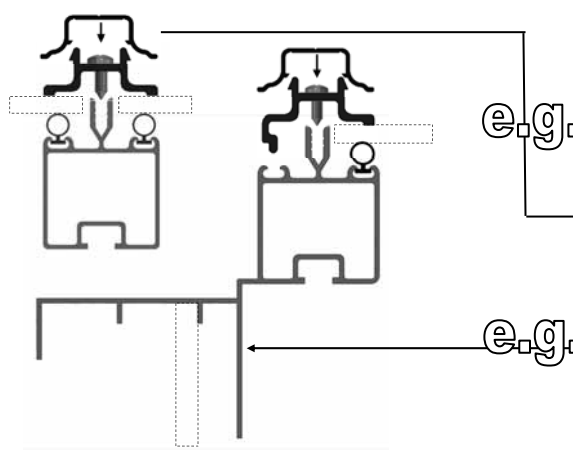
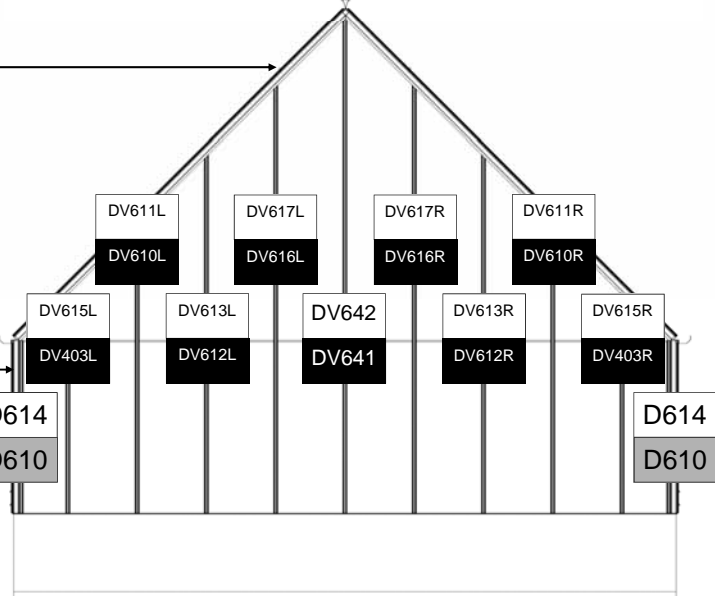
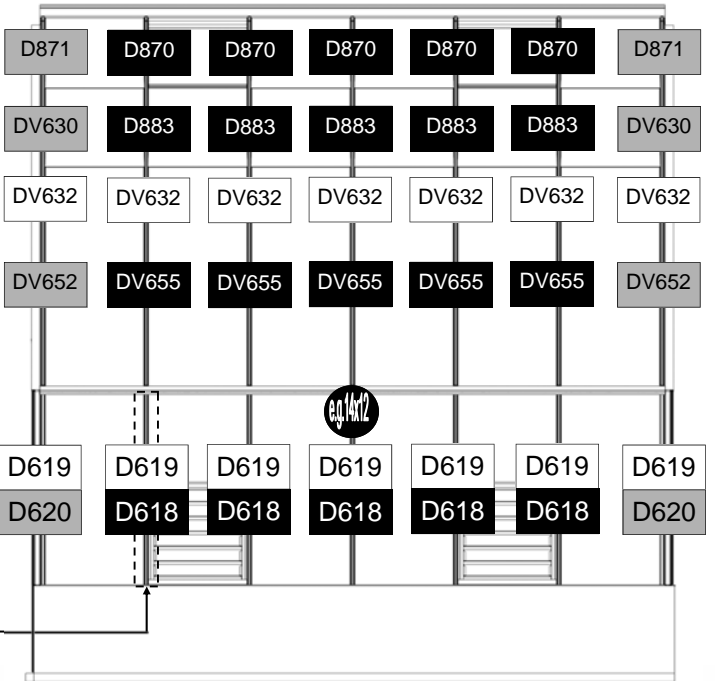

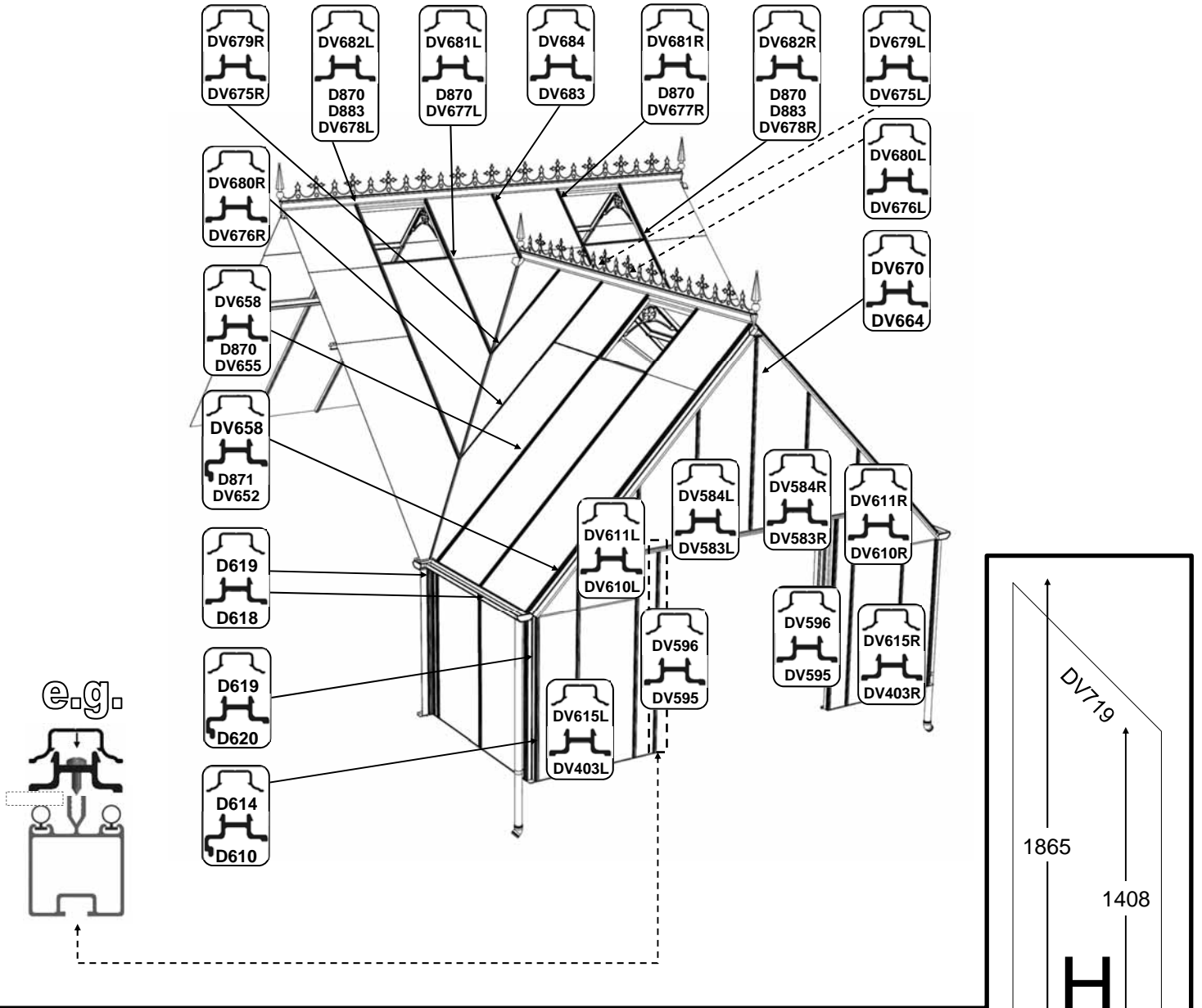

Optional extra door in gable caps, covers and glass codes.

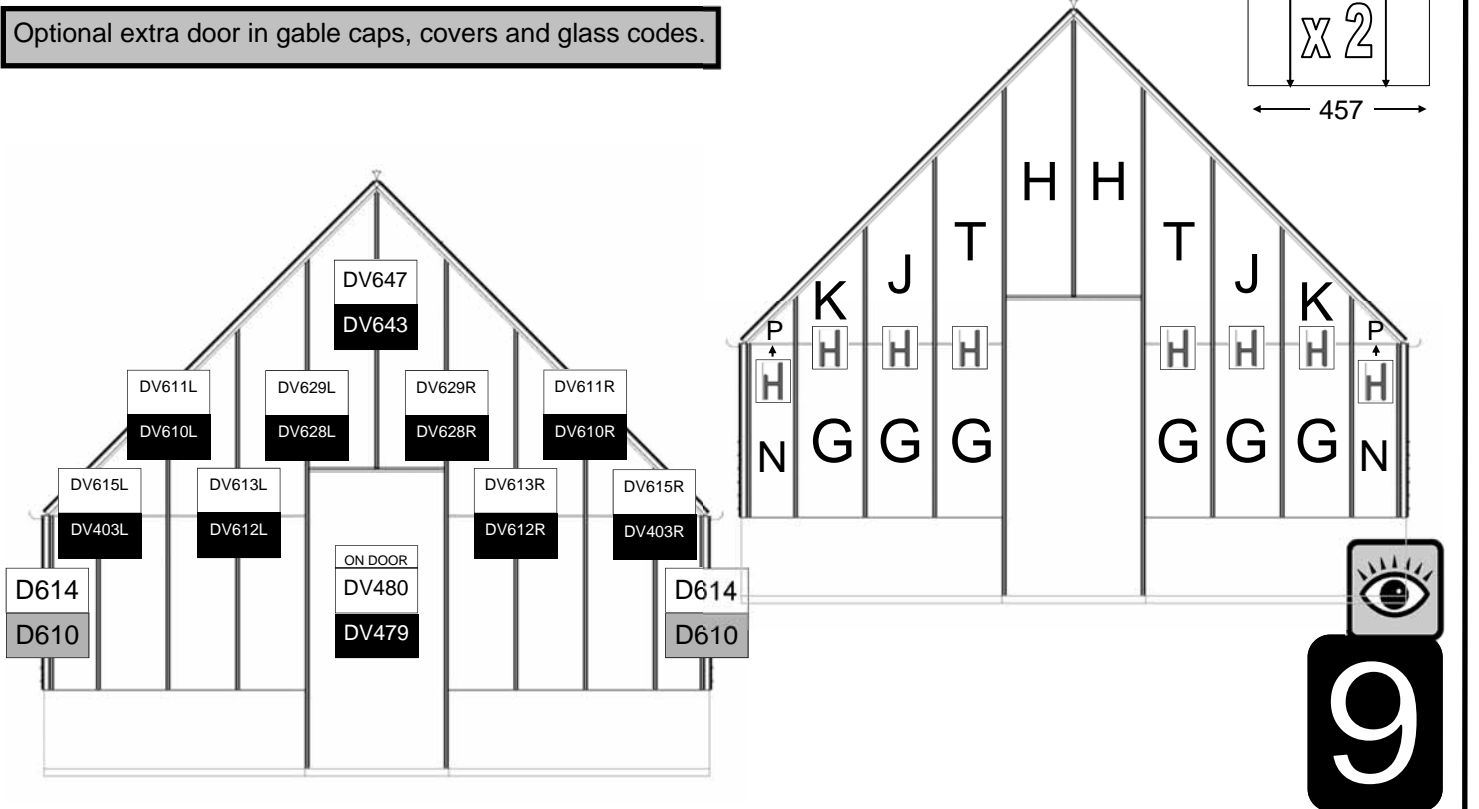

VICTORIAN RUFFORD GLASS

| PART No | | Size (mm) | 12' | 20' | 28' | 36' | 44' |
|---------------|---|----------------------------------|-----|-----|---------------------|-----|-----|
| D624 | M | 610 X 550 | 2 | 6 | 6 | 10 | 10 |
| D1216 | S | 610 X 1162 | 8 | 12 | 20 | 24 | 32 |
| DV704 | R | 610 X 1890 | 10 | 18 | 26 | 34 | 42 |
| D869 | E | 610 X 685 | 8 | 16 | 24 | 32 | 40 |
| D1208 | A | 610 X 610 | 18 | 26 | 34 | 42 | 50 |
| D625 | N | 305 X 1162 | | | 6 | | |
| D769 | G | 457 X 1162 | | | 18 | | |
| DV589 | D | 298 X 1384 | | 4 | FITTED | | |
| DV593 | W | 157 X 1468 | | 2 | | | |
| DV736 | B | 56 X 1162 | | 4 | | | |
| DV507 | P | ANGLE | | | 6 | | |
| DV713 | K | ANGLE | | | 6 | | |
| DV714 | J | ANGLE | | | 4 | | |
| DV715 | U | ANGLE | | | 2 | | |
| DV716 | T | ANGLE | | | 4 | | |
| DV717 | Z | ANGLE | | | 2 | | |
| DV718 | F | ANGLE | | | 4 | | |
| DV725 | Q | ANGLE | | | 2 | | |
| DV726 | X | ANGLE | | | 2 | | |
| DV728 | Y | SPECIAL ANGLE | | | 2 | | |
| DV729 | C | ANGLE | | | 2 | | |
| DV733 | V | ANGLE | | | 4 | | |
| DV581/B | | 1838mm | | | 1 | | |
| D101 / ROSEPS | | 610 long (inc cuts to 457&305mm) | | | 21 + (1 per louver) | | |

IMPORTANT:

e.g.

On the roof sections please make sure that you place a screw around 25mm / 1" from the bottom of each capping strip (create a hole in the plastic if required) and that the screws are nice and tight to avoid any glass slippage.

On the roof the smaller upper roof panes overlap the lower roof panes by 10-15mm.

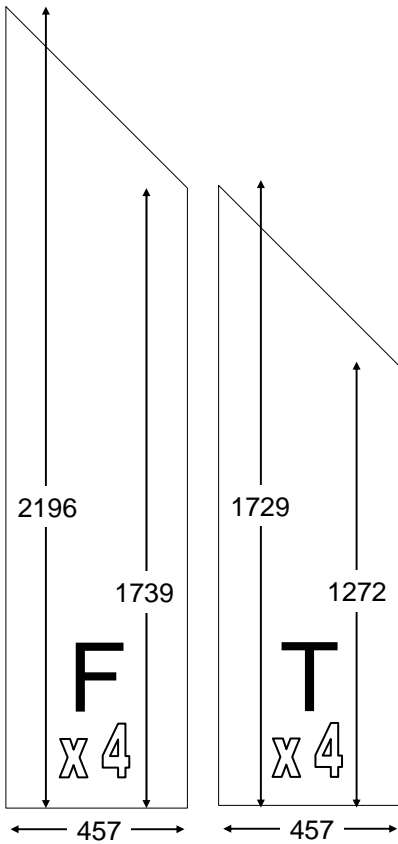
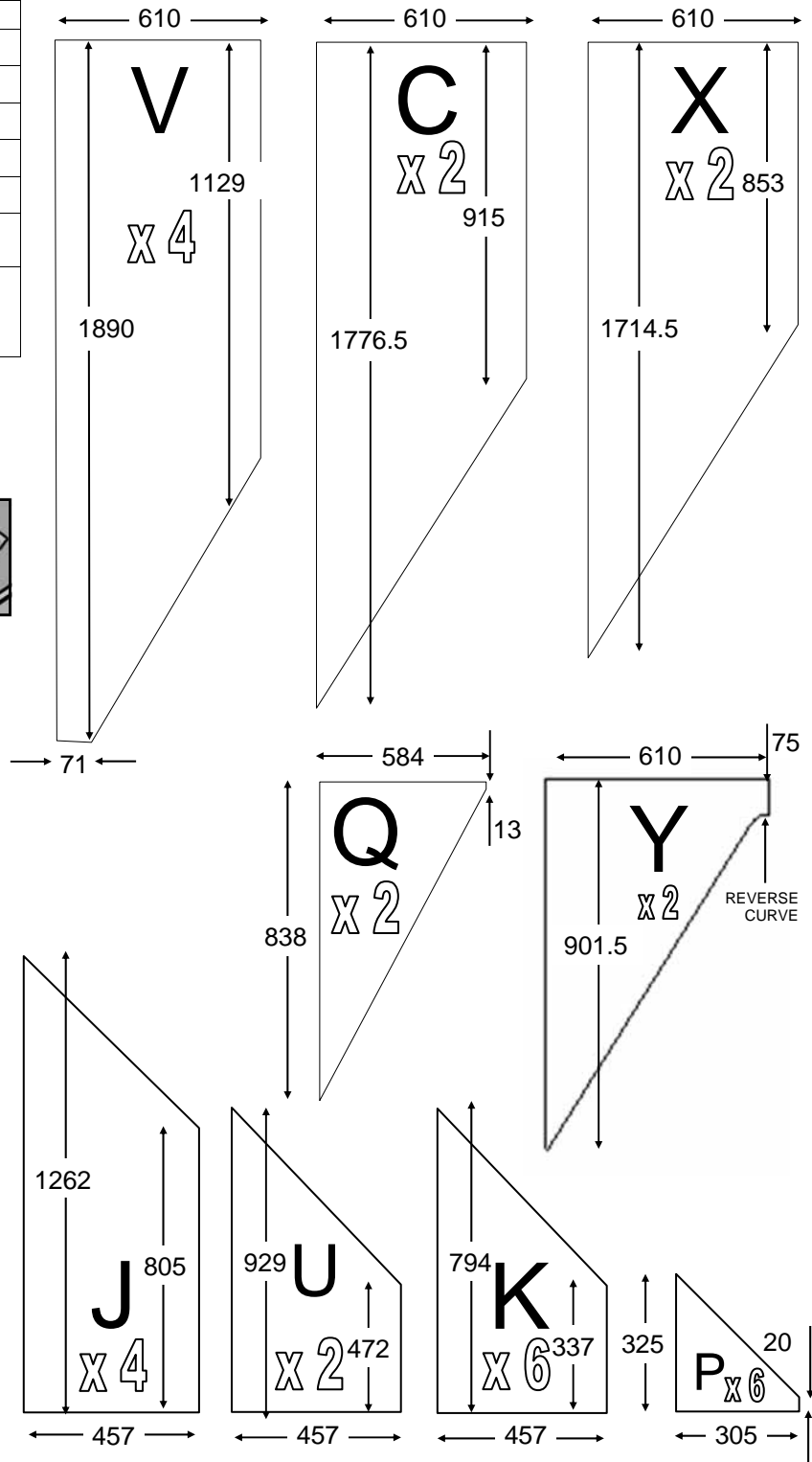
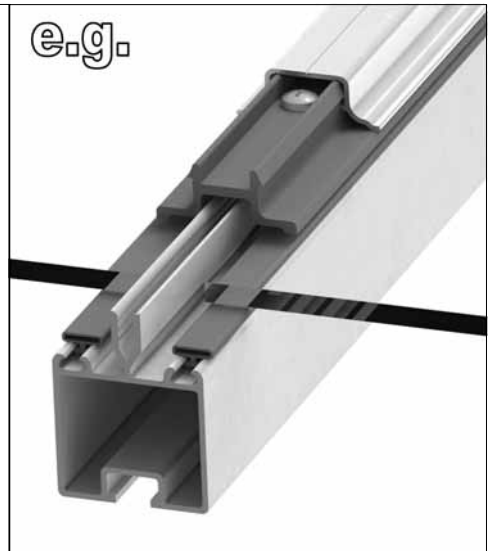

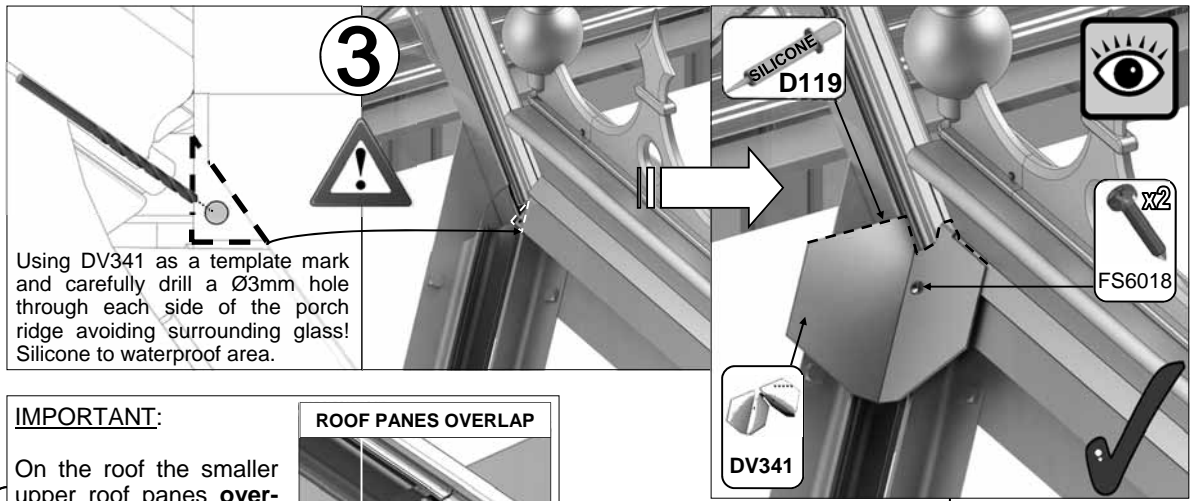

IMPORTANT:

ROOF PANES OVERLAP

On the roof the smaller upper roof panes **overlap** the lower roof panes by 10-15mm.

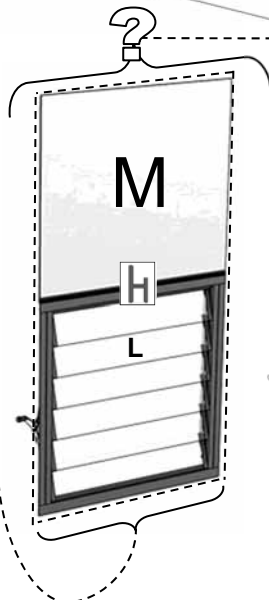
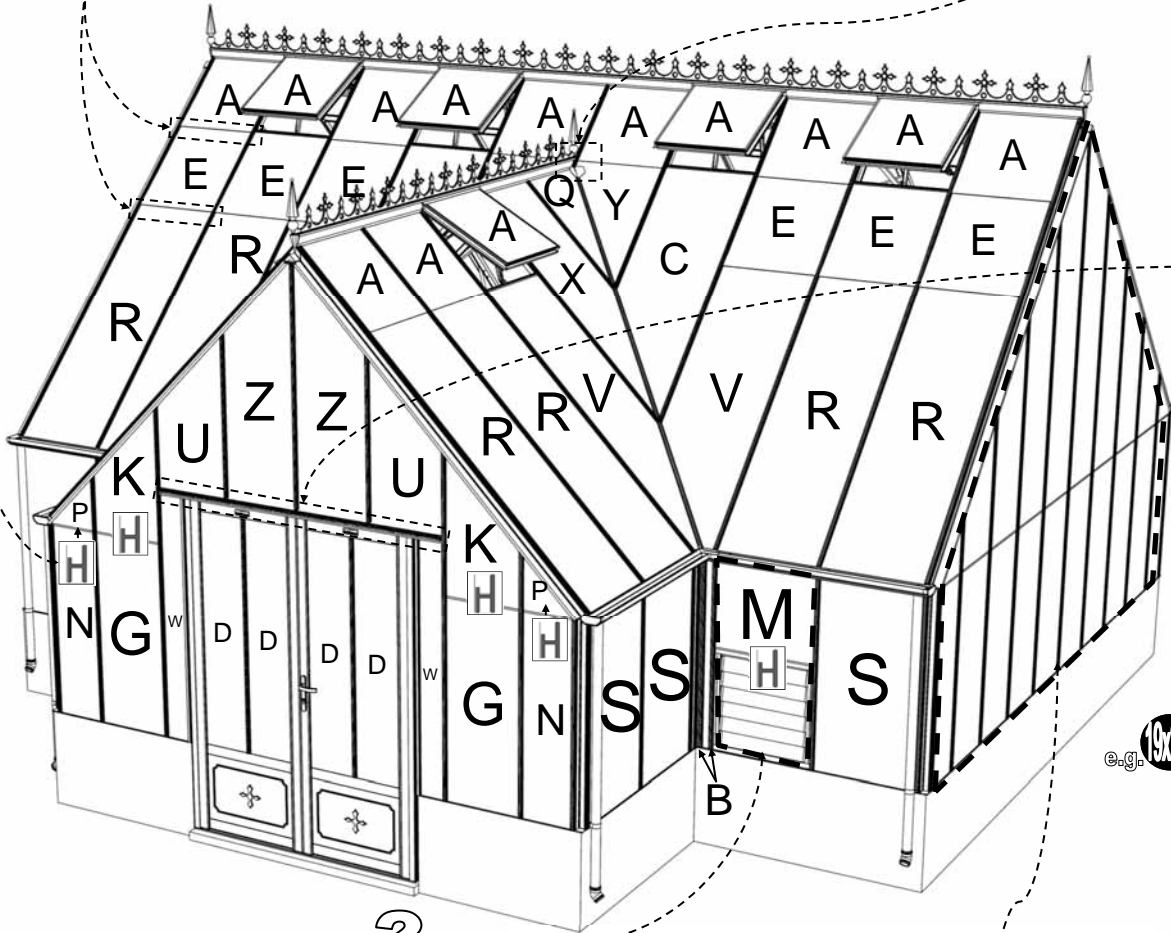
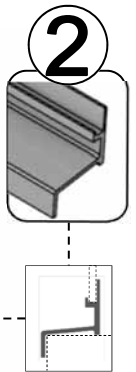
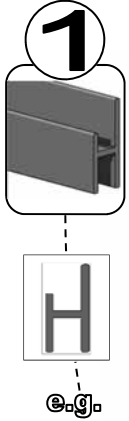
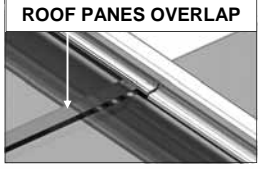

| PART | | Size (mm) | |
|---------------|---|-----------|---|
| D624 | M | 610 X 550 | 1 |
| D729 | L | 525 X 100 | 6 |
| D101 / ROSEPS | H | 610 long | 1 |

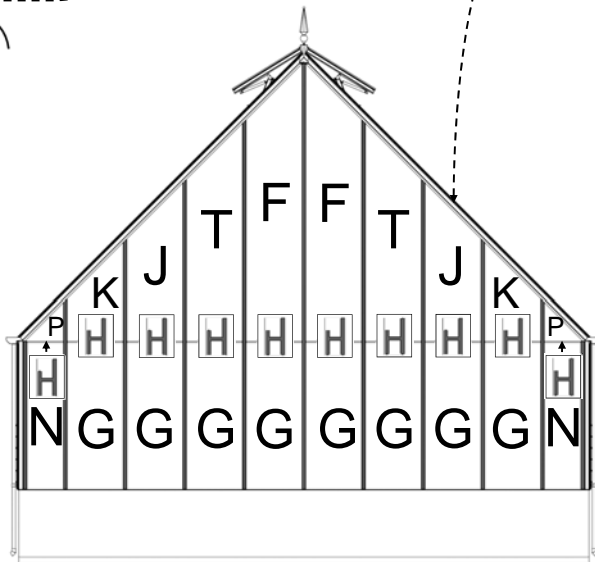

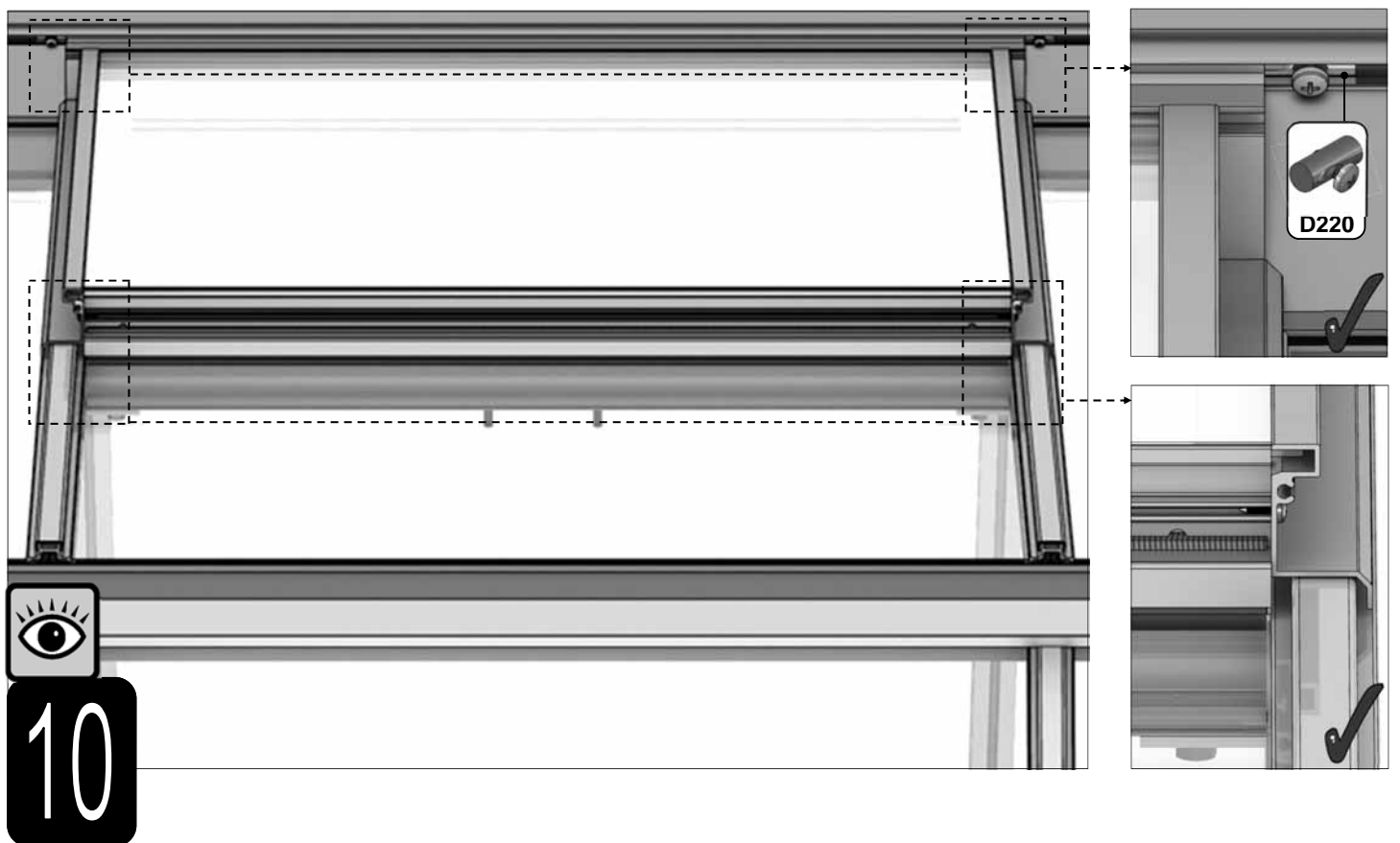
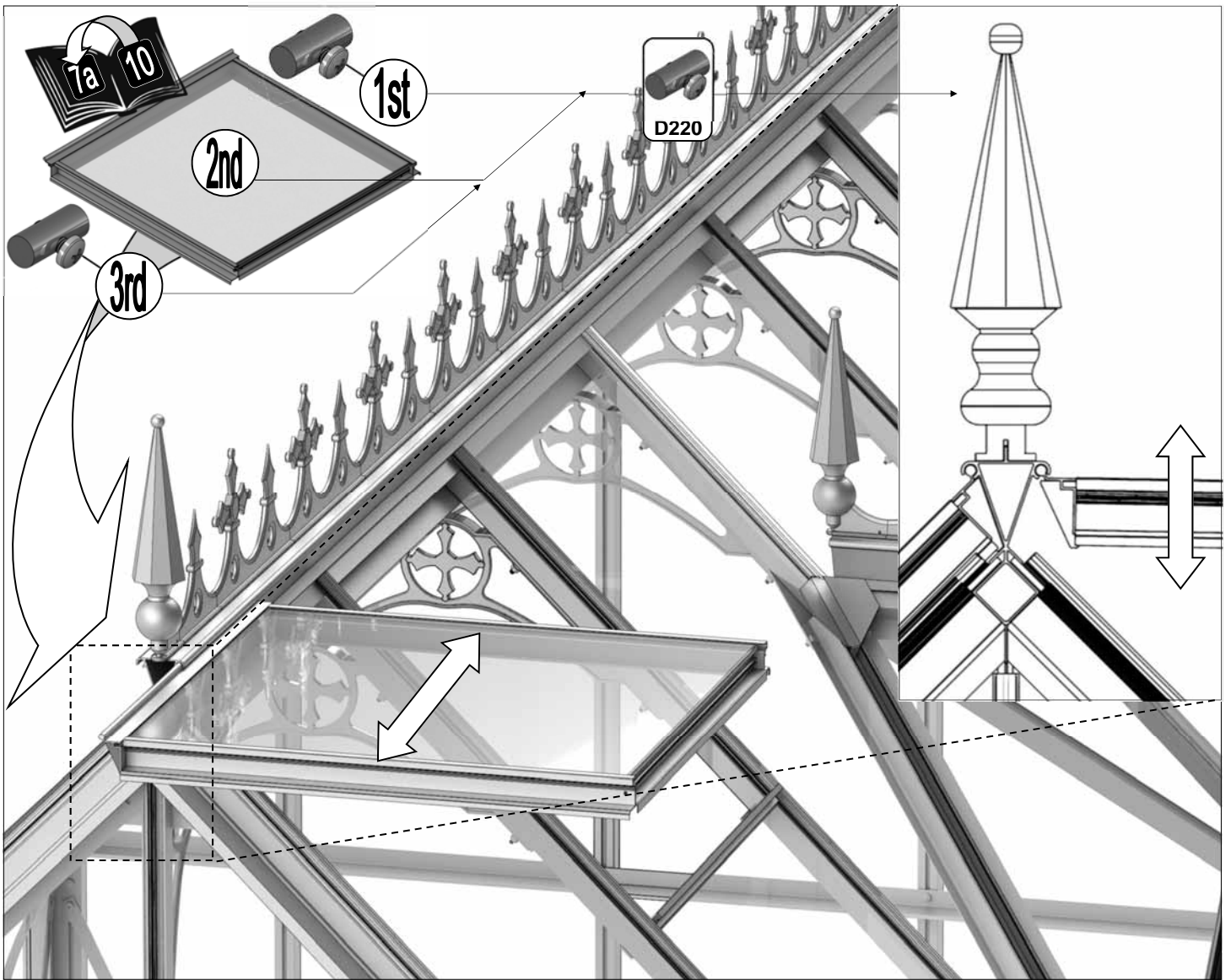

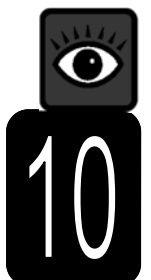
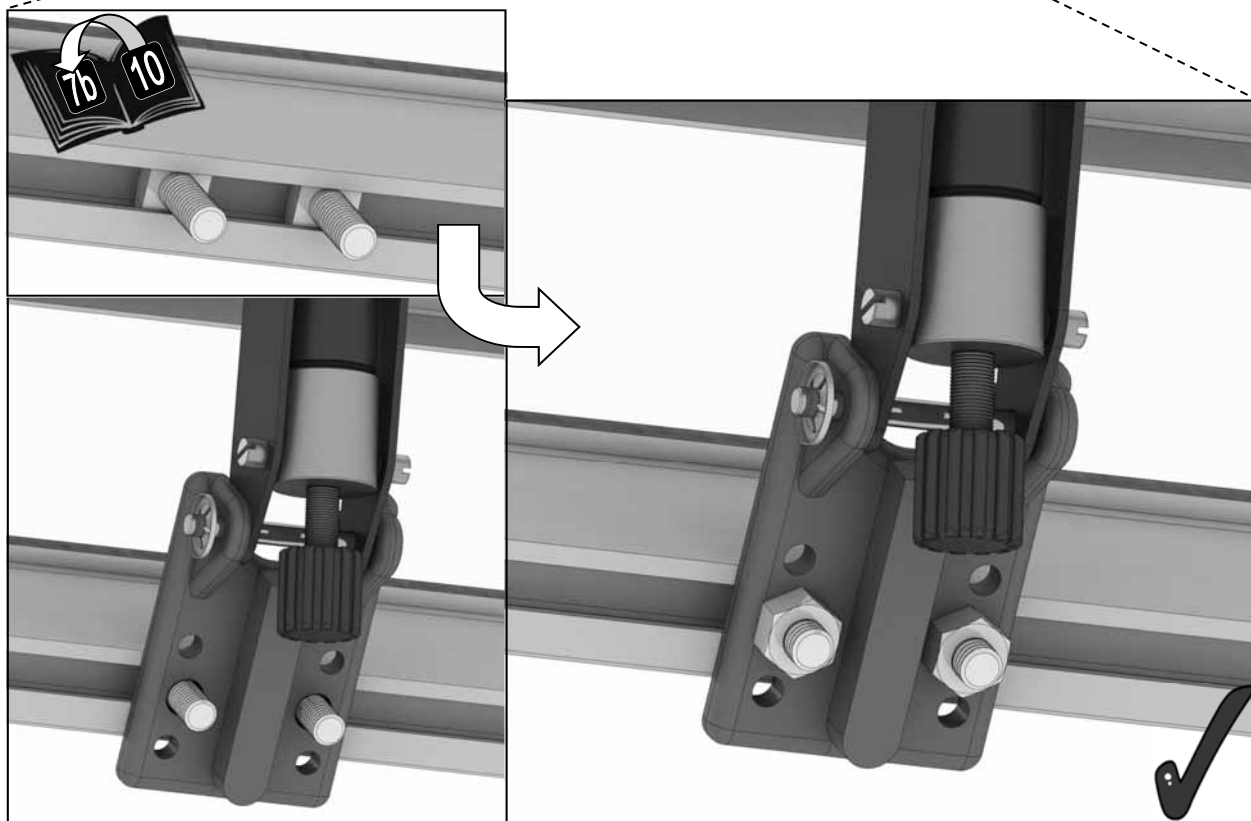
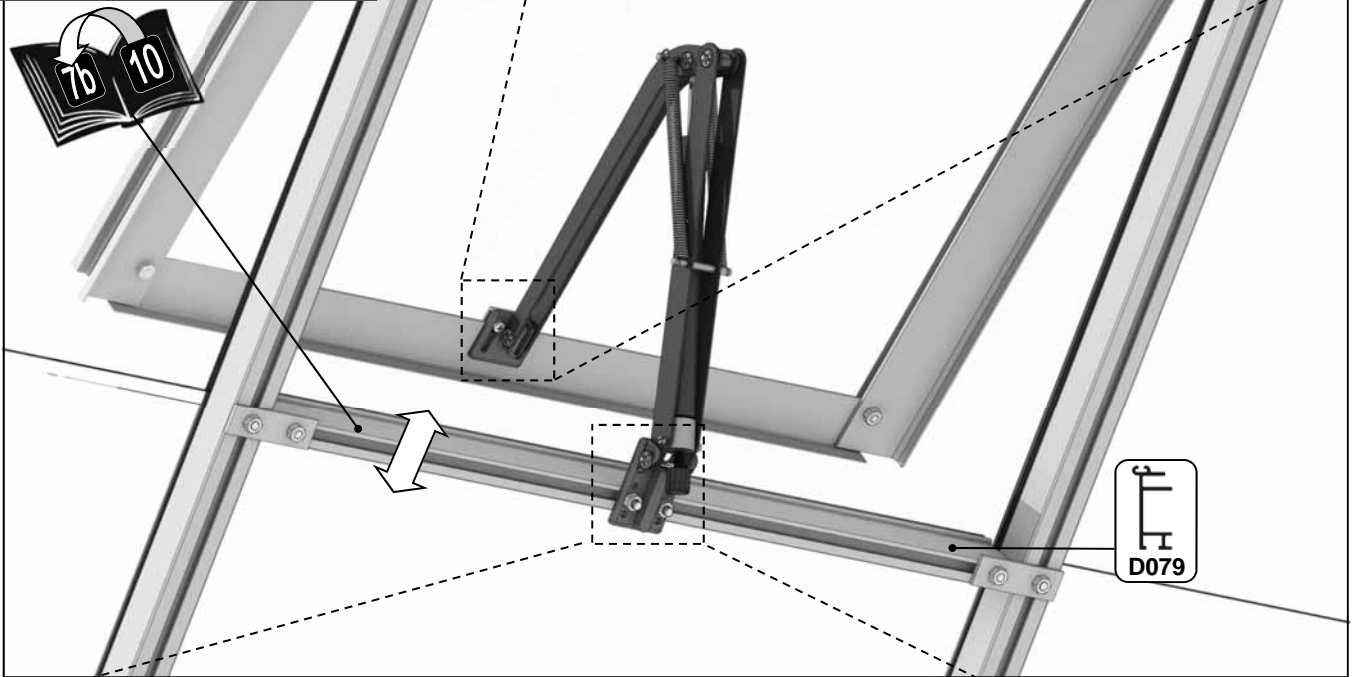
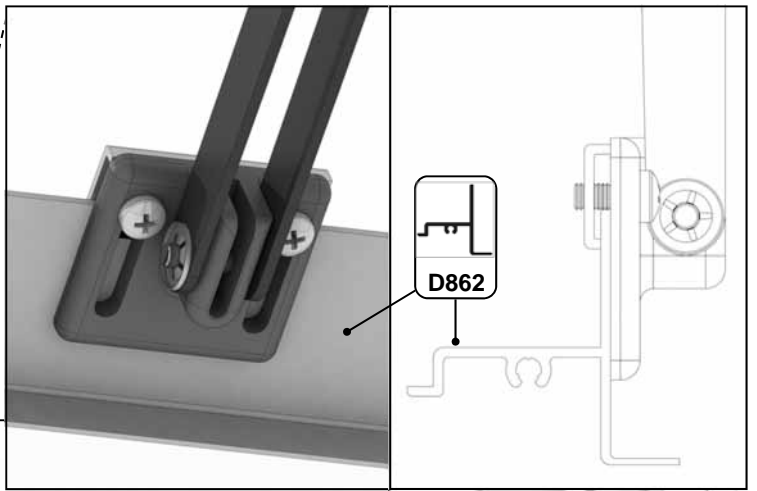

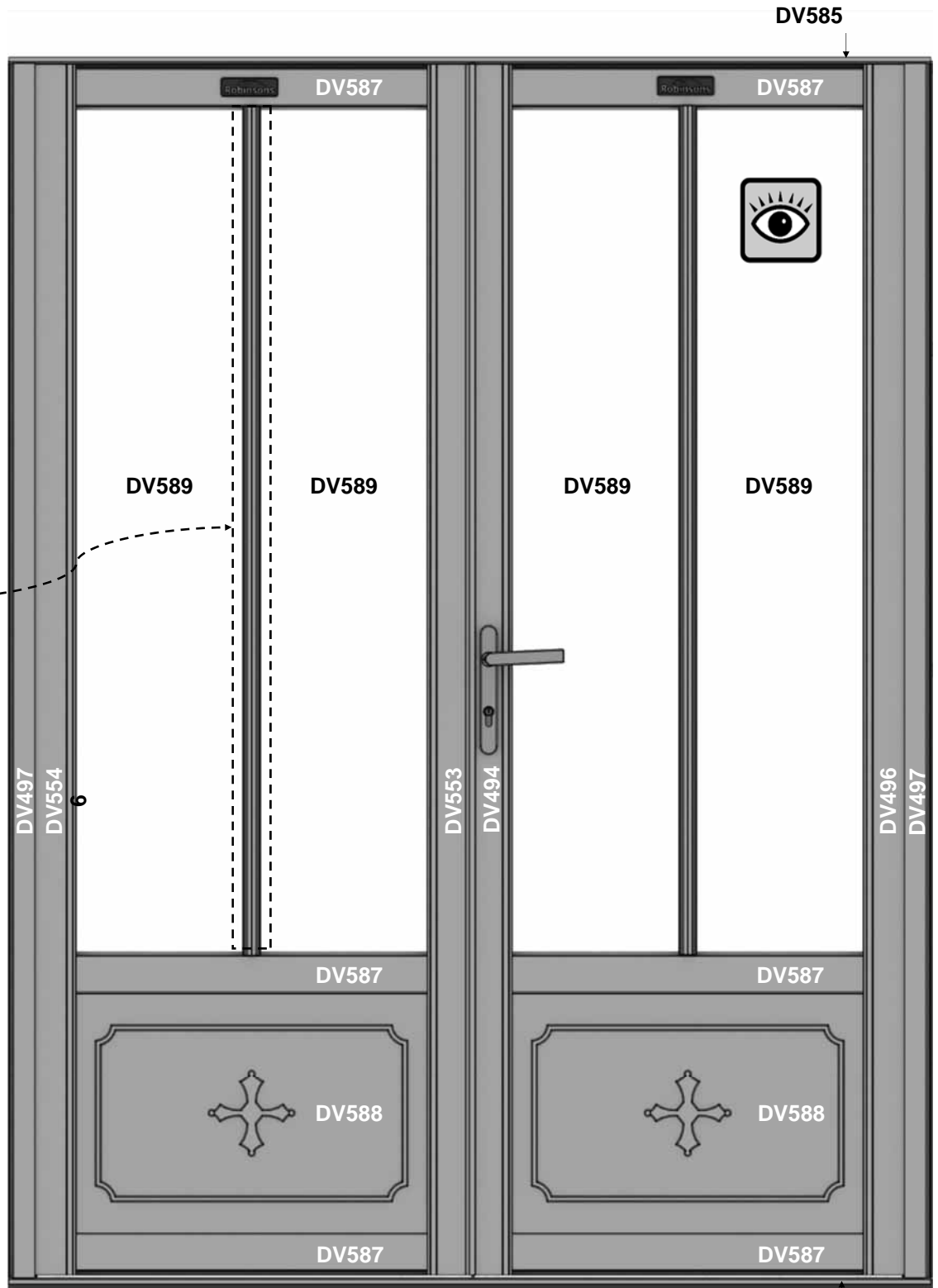
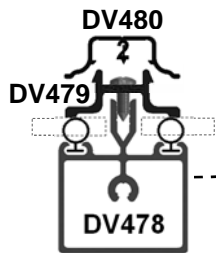
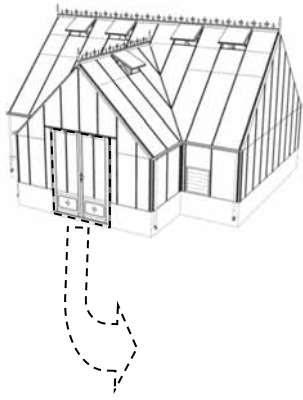

MAIN COMPONENTS OF YOUR PRECONSTRUCTED DOORS

| Part No | mm | Quantity |
|-----------|-----------|----------|
| DV478 | 1384 | 2 |
| DV479 | 1384 | 2 |
| DV480 | 1384 | 2 |
| DV494 | 1974 | 1 |
| DV496 | 1974 | 1 |
| DV497 | 1979.5 | 2 |
| DV553 | 1974 | 1 |
| DV554 | 1974 | 1 |
| DV585/alu | 1503 | 1 |
| DV585/Stl | 1503 | 1 |
| DV587 | 700 | 6 |
| DV588 | 602.5X390 | 2 |
| DV589 | 298X1384 | 4 |



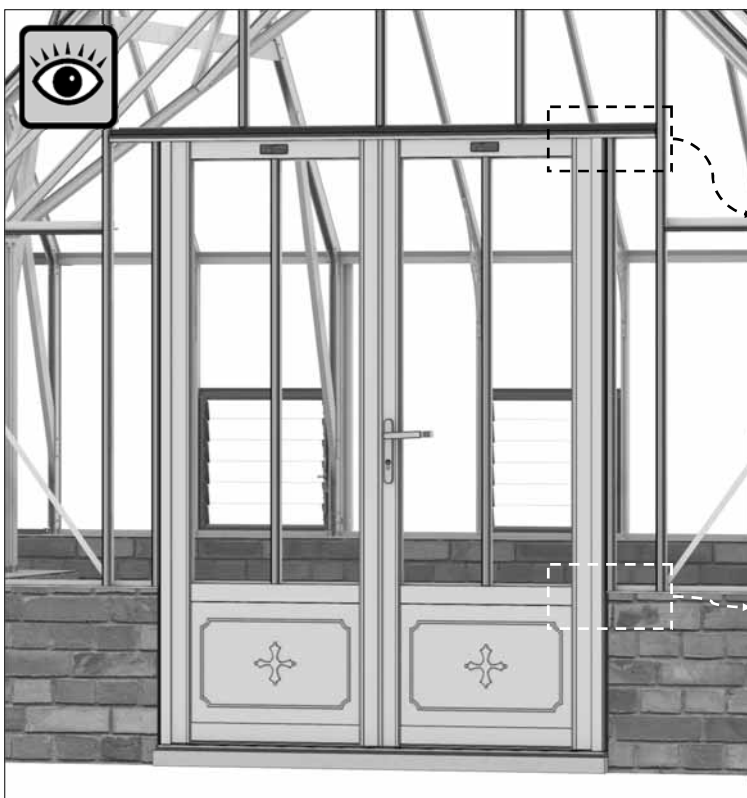
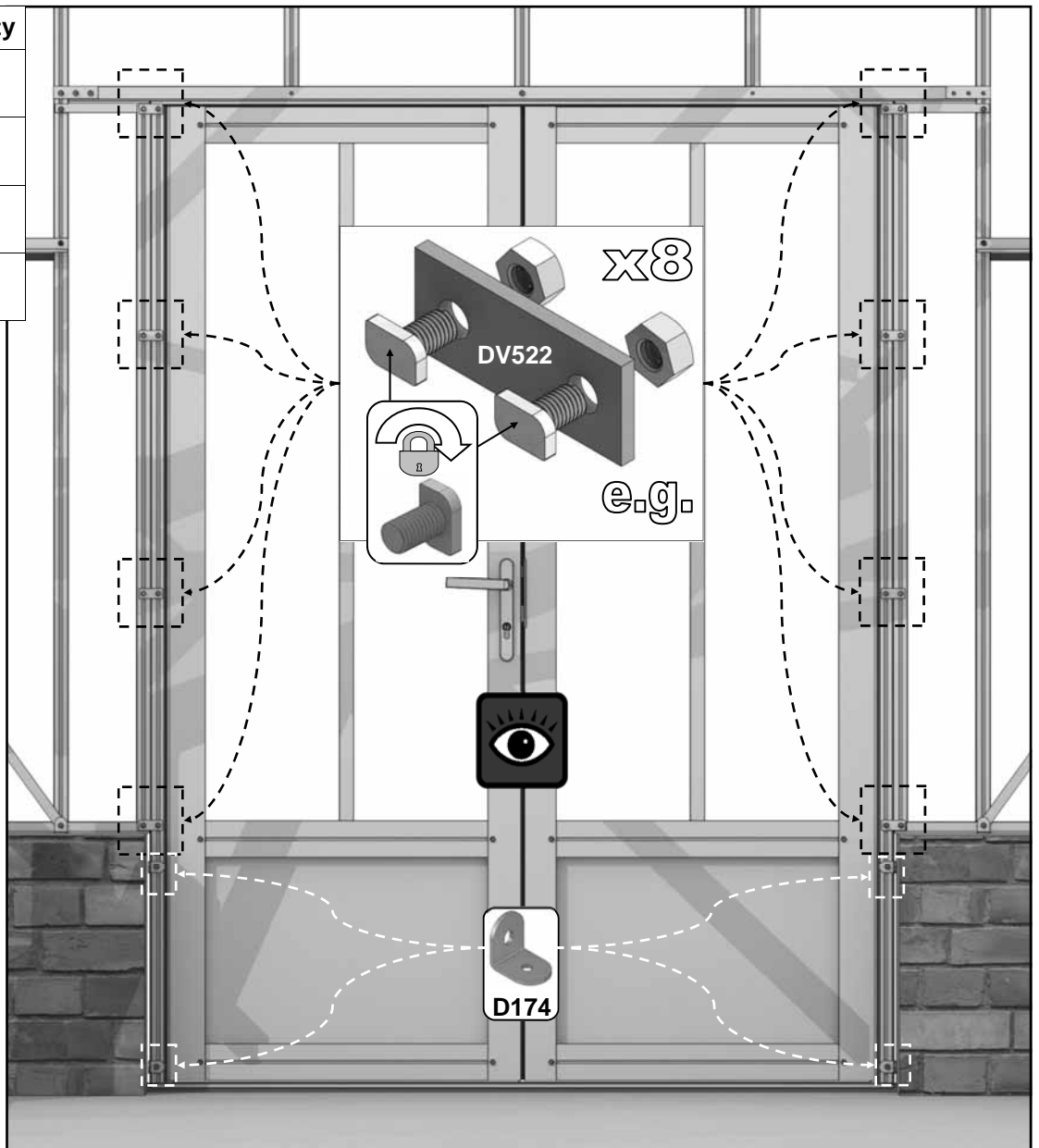

| Part No | | Quantity |
|--------------------|---|----------|
| D522 |  | 8 |
| D174 |  | 4 |
| HE569 CROP BOLT |  | 20 |
| FS6504 M6 NUT |  | 20 |

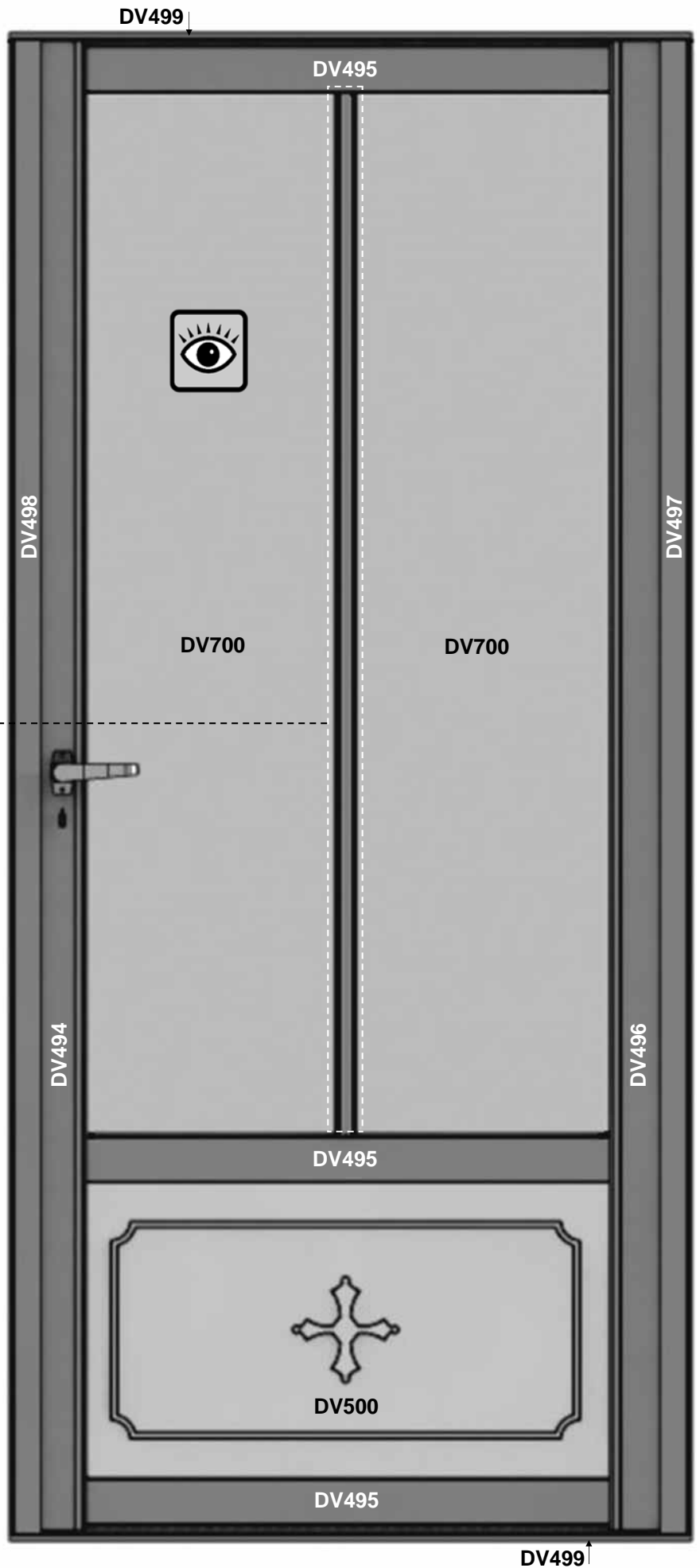
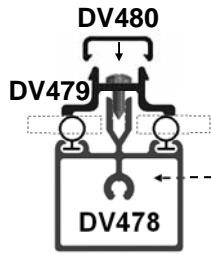
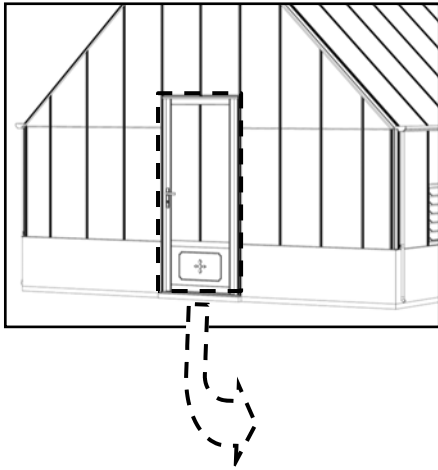

Optional Gable End Door



| Part No | | Quantity |
|--------------------|---|----------|
| D522 |  | 10 |
| HE569 CROP BOLT |  | 20 |
| FS6504 M6 NUT |  | 20 |

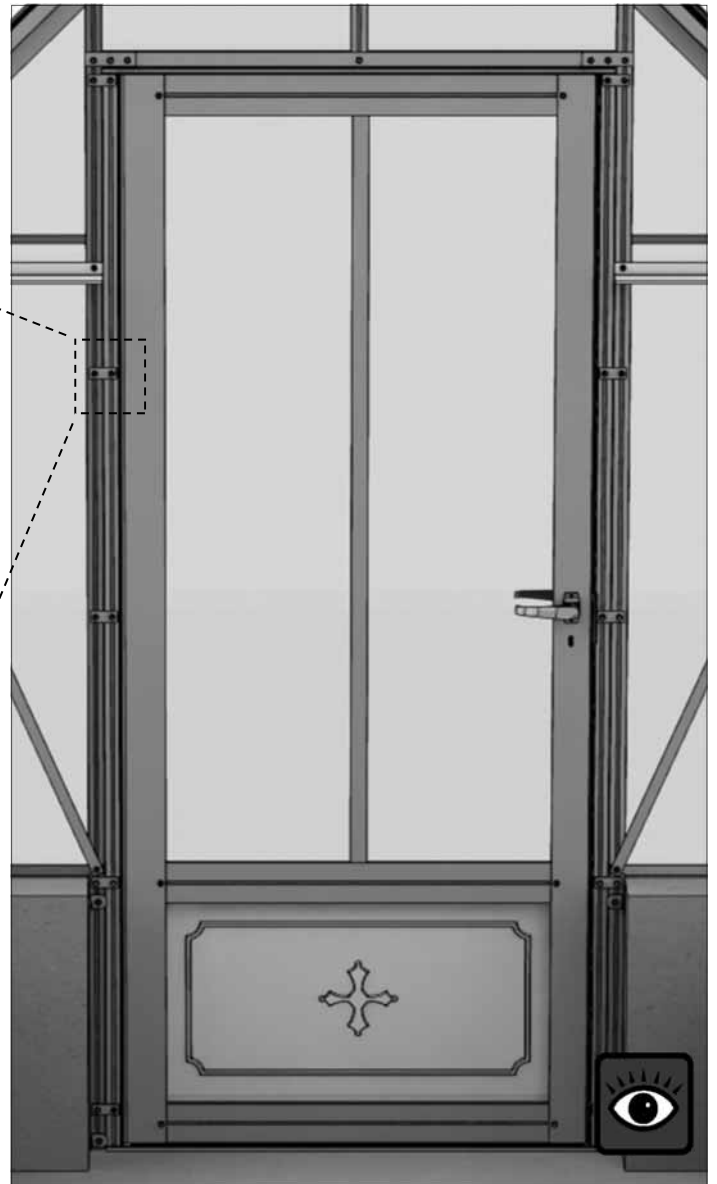
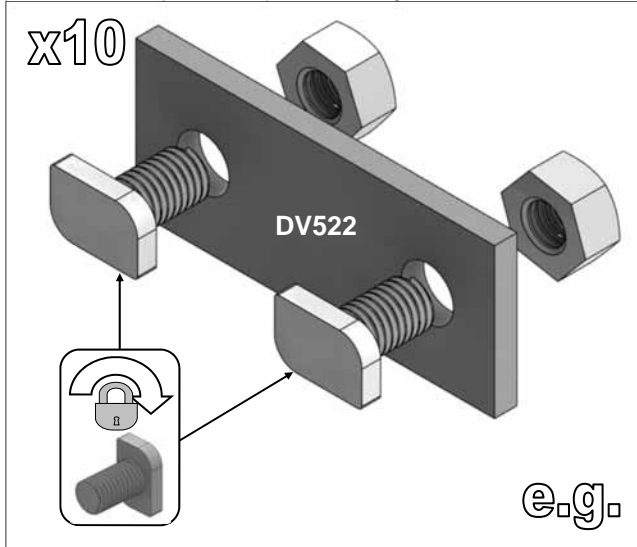

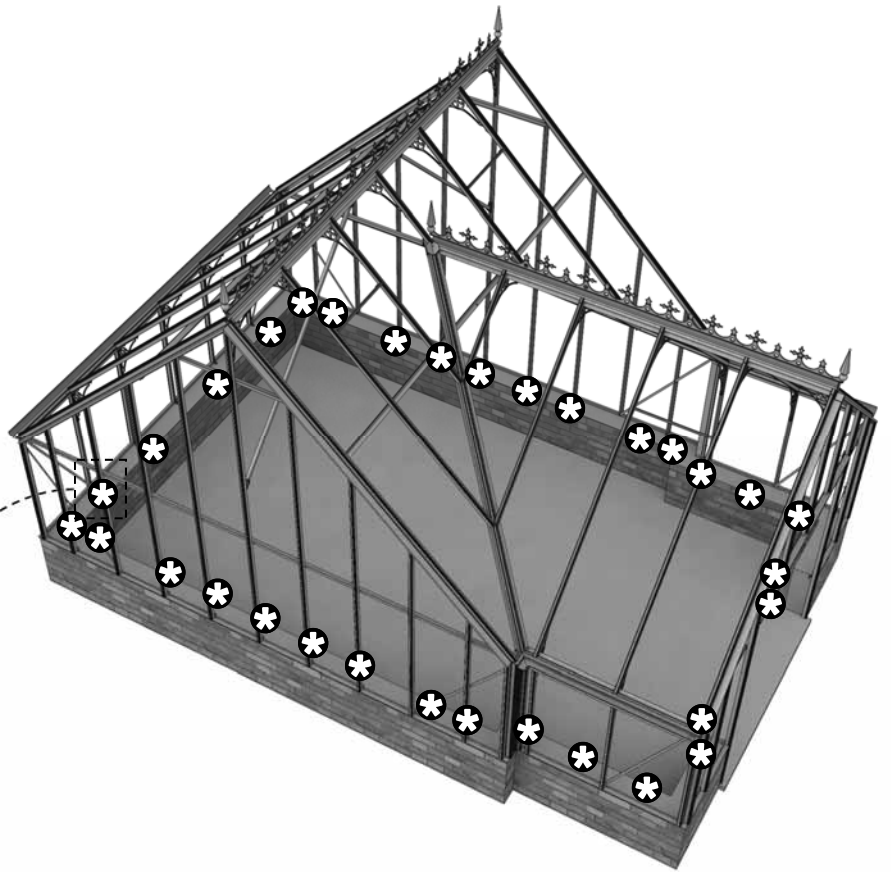
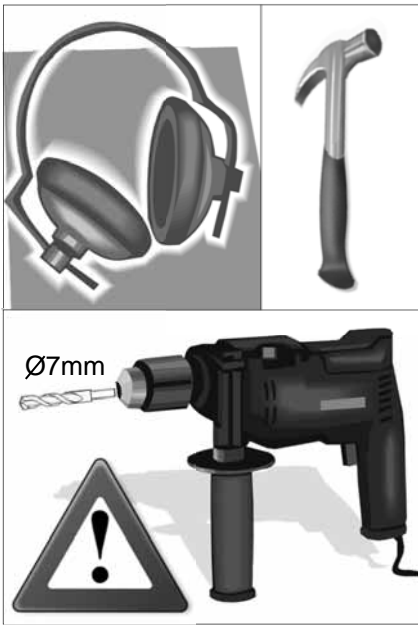

e.g.

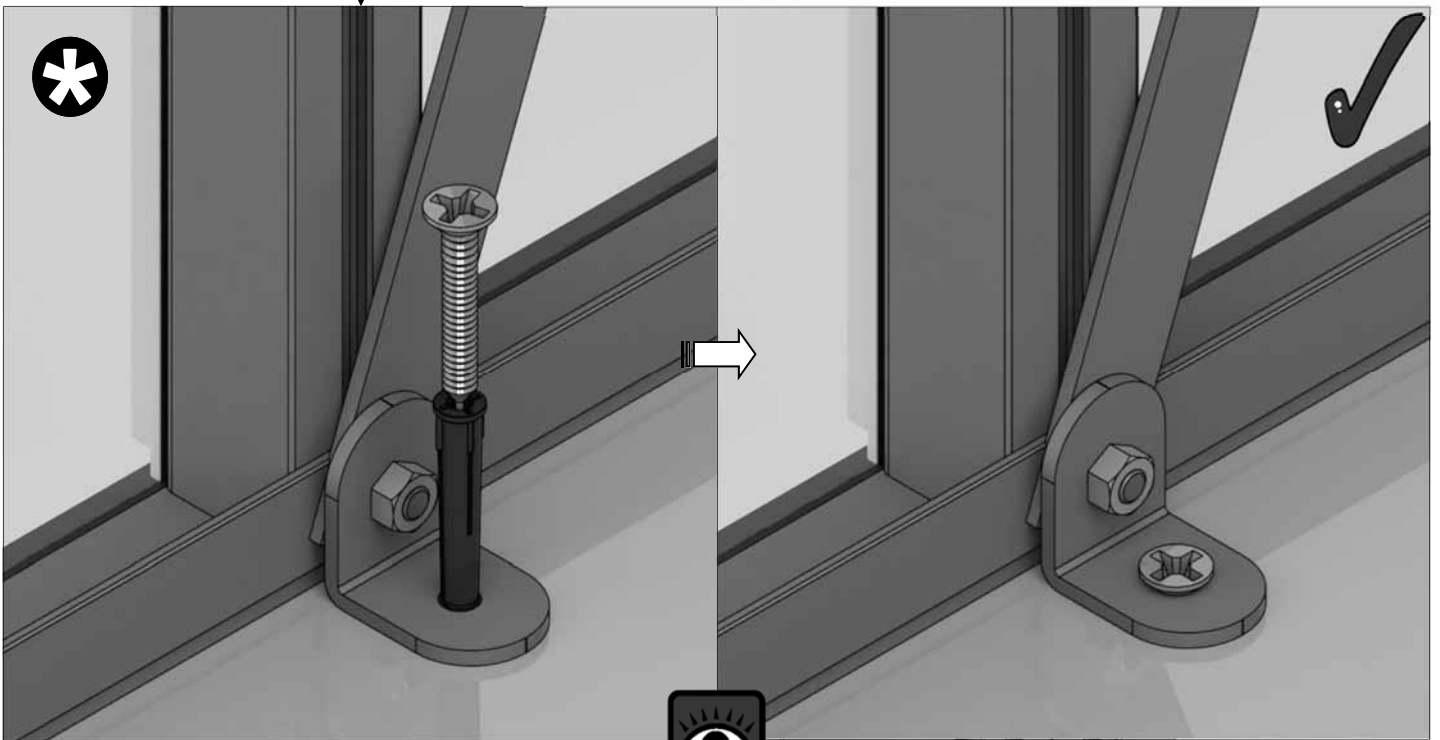

12+ MODELS ONLY



12

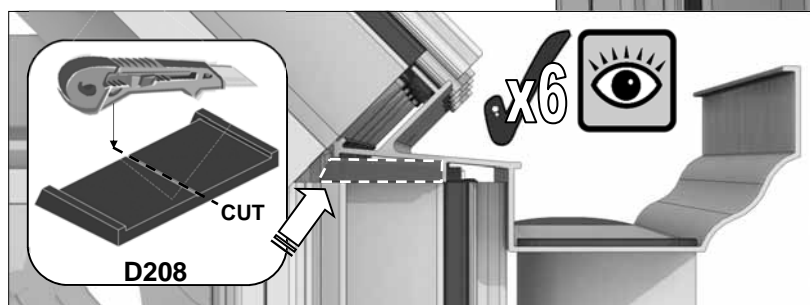
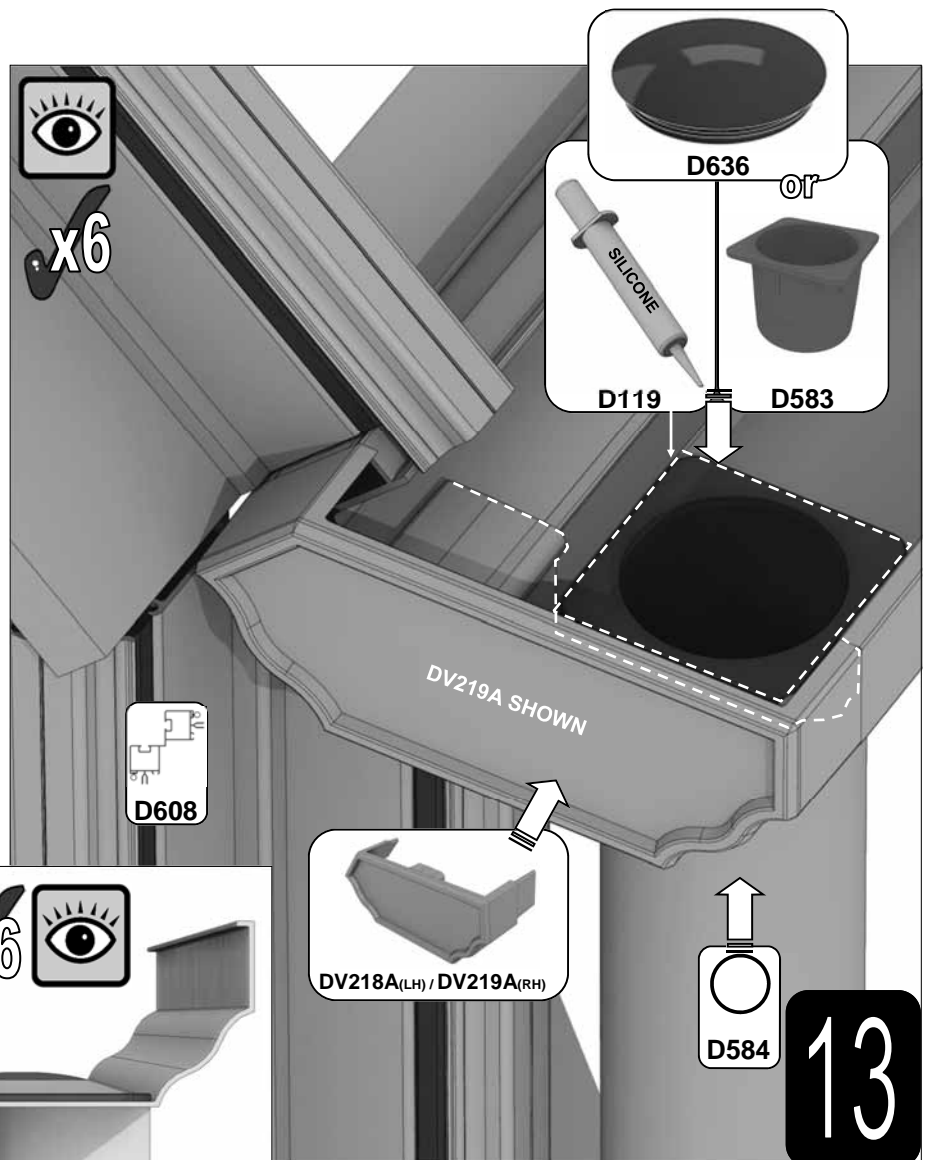
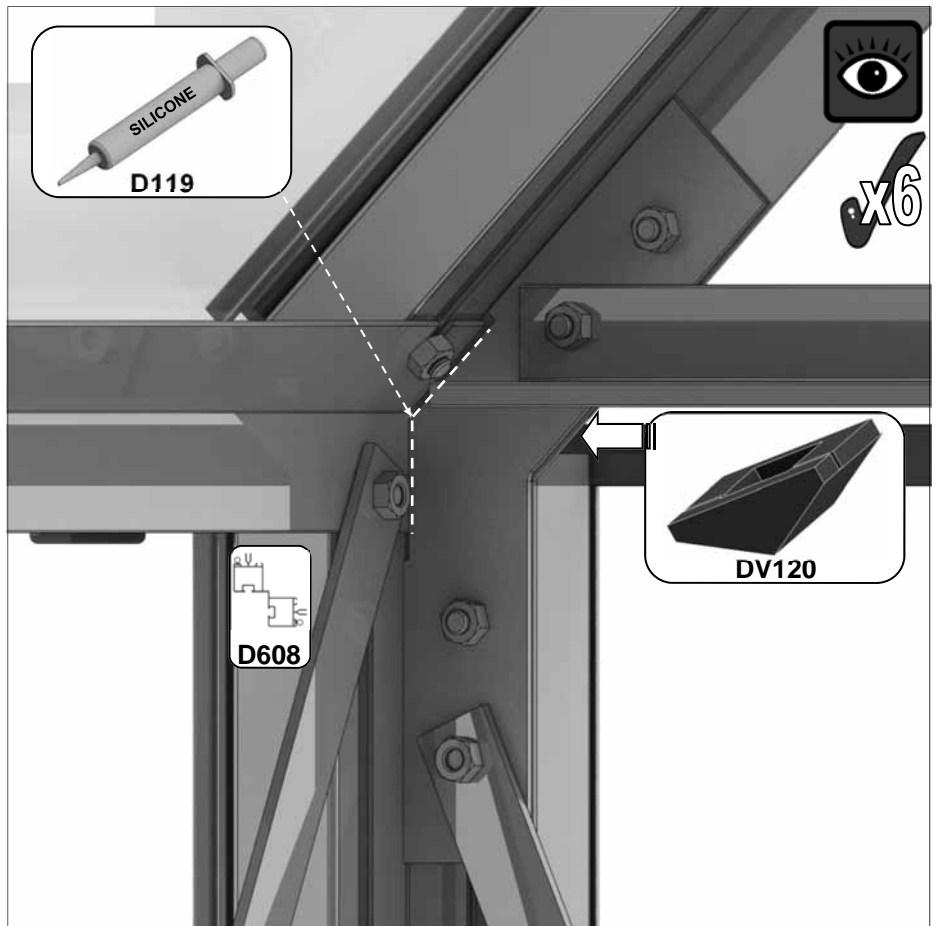
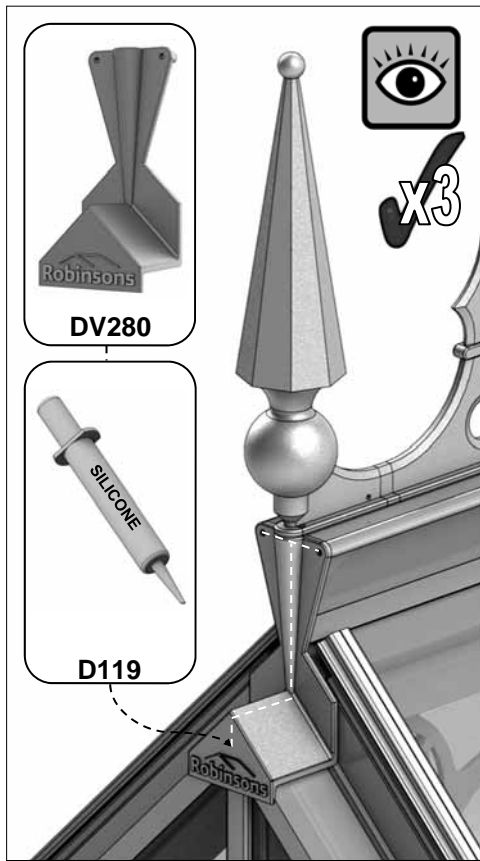

Joining gutters at extensions

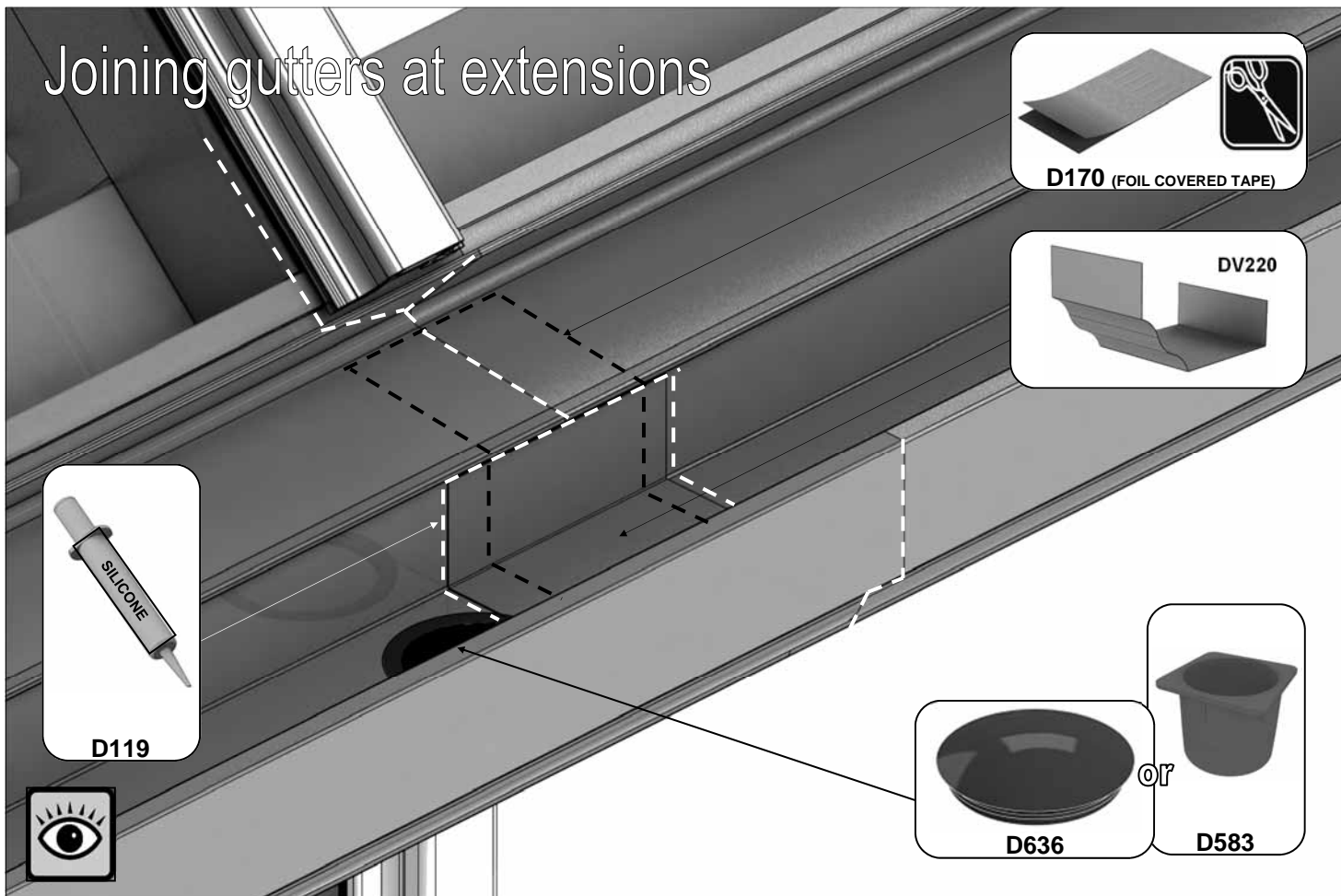

Fitting the optional Robinsons 2.5m blinds to the Rufford

With the main roof bars on this model being 3110mm long you can not fit the 2500mm long blinds at the top abutting the ridge like on smaller models, see the separate instructions with your blinds. You will need to offset the blinds from the ridge in order that they are long enough to reach all of the way down to your gutter after also flexing around your horizontal roof purlings. We recommend fitting the blinds just below your roof vents, level with the bottom of your vent slam rails, D079's, see below. Check after doing one that the fabric stretches down fully to the gutter level blind hooks incase the top mounts need offsetting more. Though the blinds do not go all of the way to the ridge line the shade created on a model this wide is still more than sufficient. You will not though be able to fit a partition blind in front of a partition on this model.

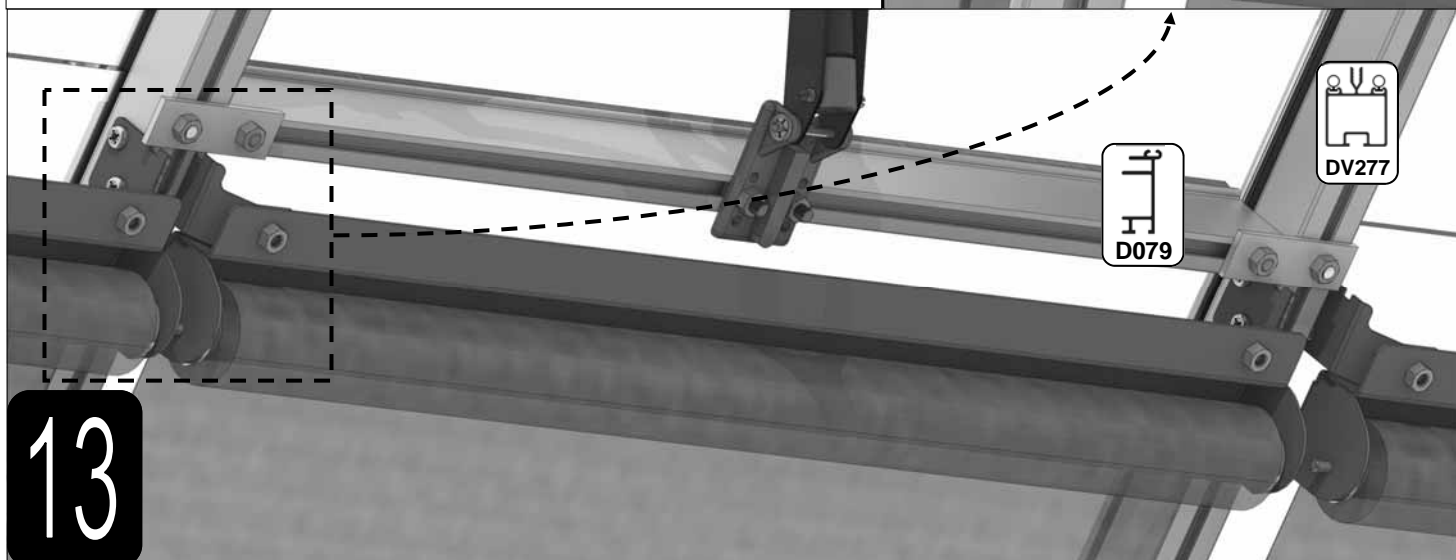
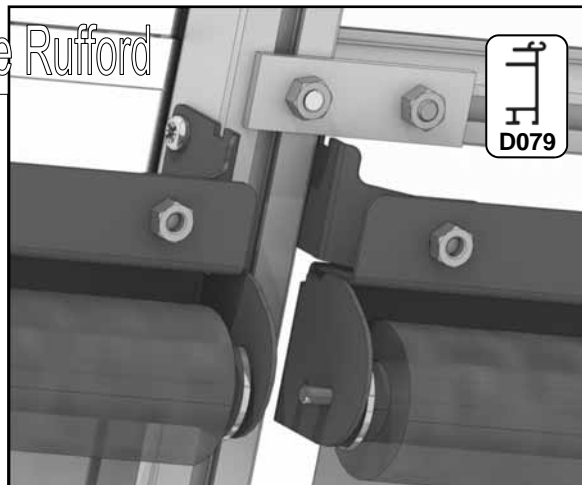

Example: 2x 4' 3 slat shelves 'ST0304' = 8' run

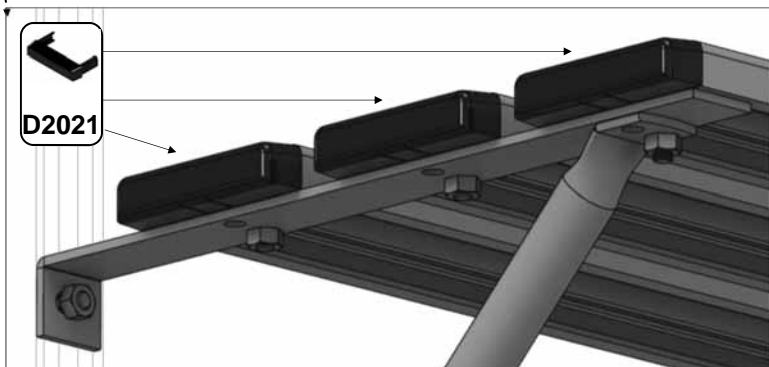
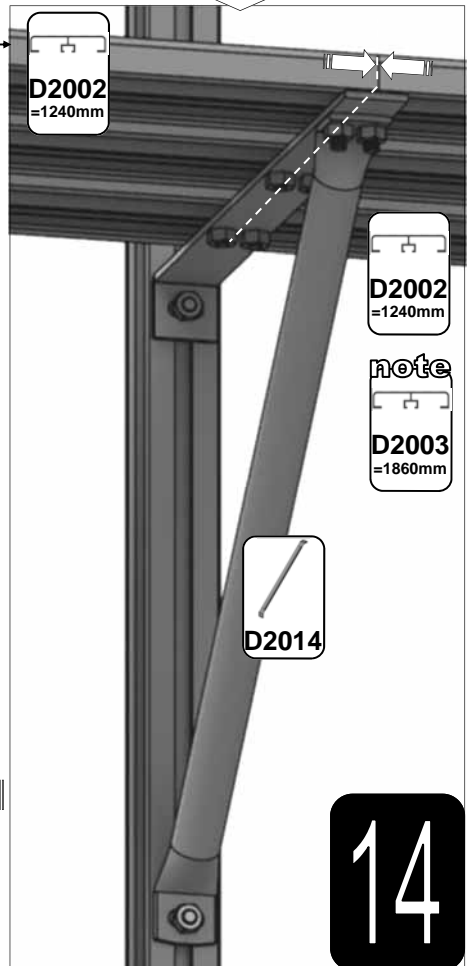
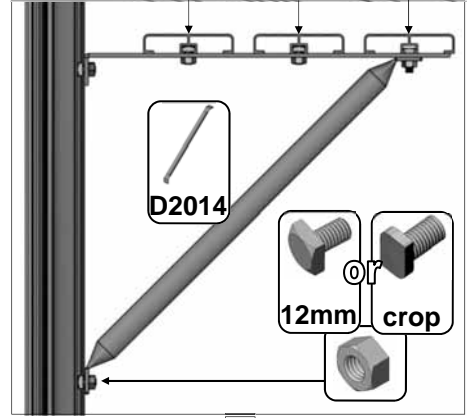
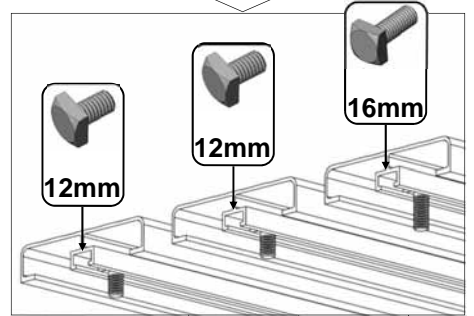
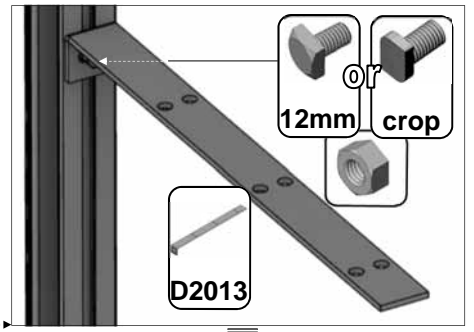
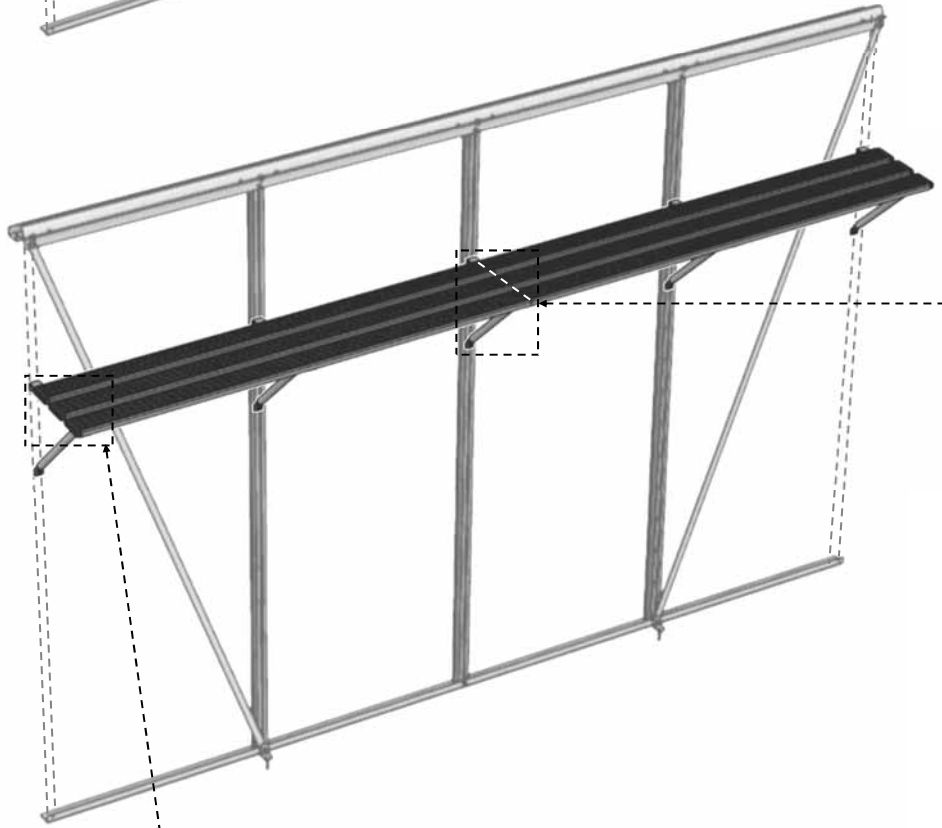
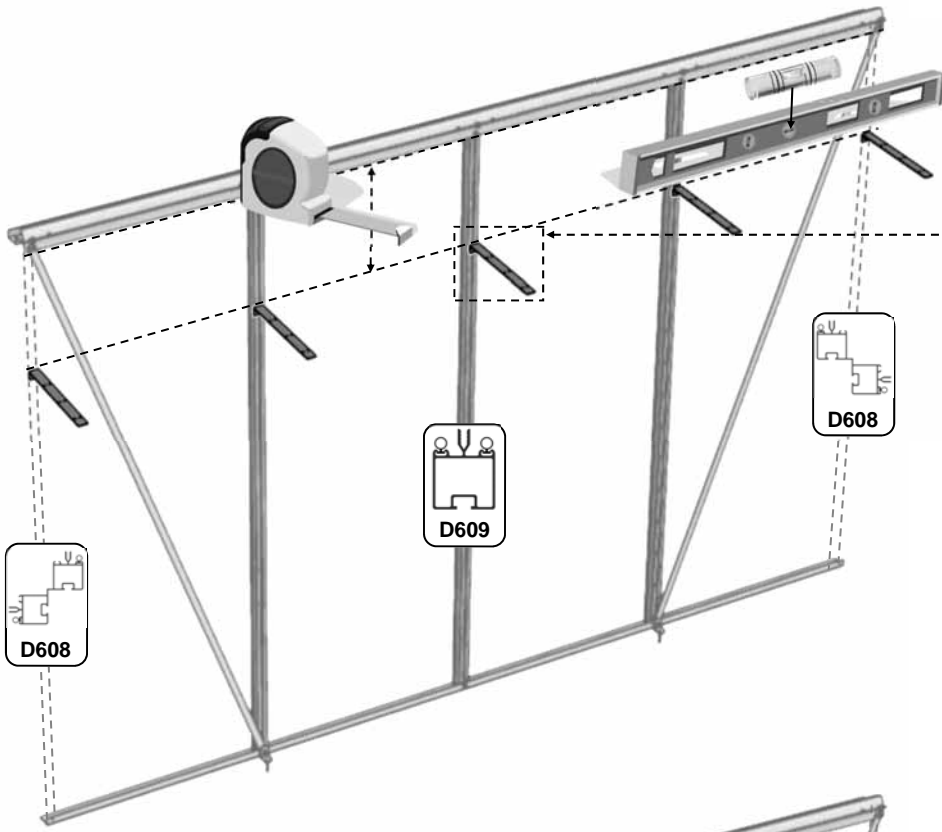

Staging around A-frames

When adapting a shelf or staging section to fit around an A-frame the slats can be cut in several ways to give a neat, level result.

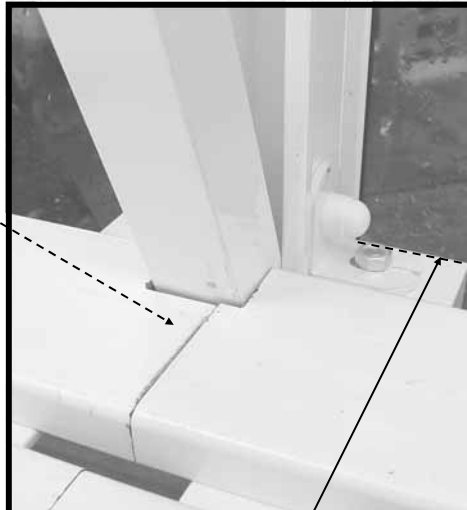
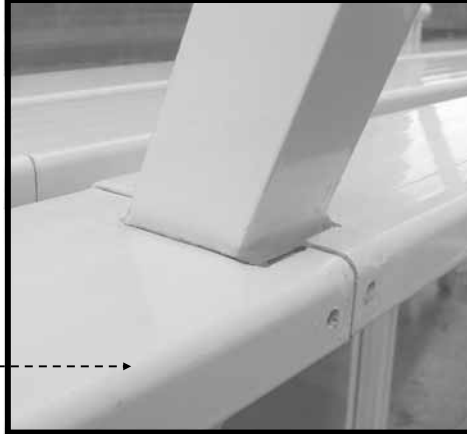

900mm up from bottom of base rail.

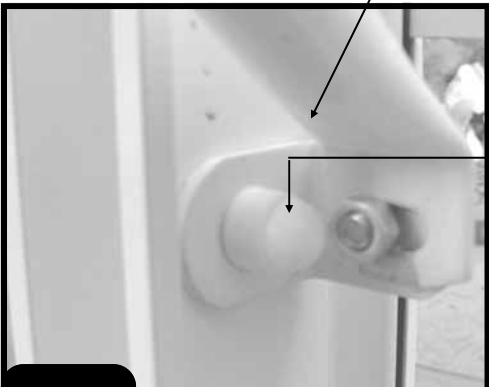
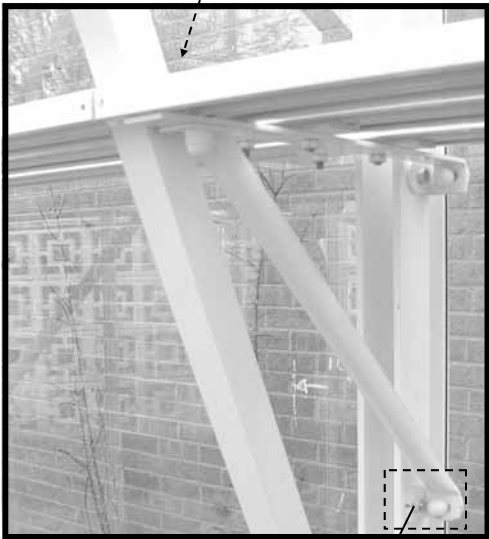

Fitting Robinsons slatted **shelving** and **staging** using the instructions is usually quite straight forward. However if you have chosen a greenhouse which includes **A-frames** or a **partition** then fitting the staging becomes more complicated. In these instances some additional adaptation brackets where A-frames are included, and some side height vertical bracings for a partition.

You need to **cut** (using a hacksaw) the staging slats to fit around the A-frames at which ever **height** you have pre-determined (we recommend **900mm** up from your base / floor for **staging**, and your **shelf** is best fitted just below your eaves spandrels DV100).

Spare **ground anchoring brackets** can be used to attach the shelf and staging supports to the side of an A-frame or **side height vertical bracing** when fitting around a partition.

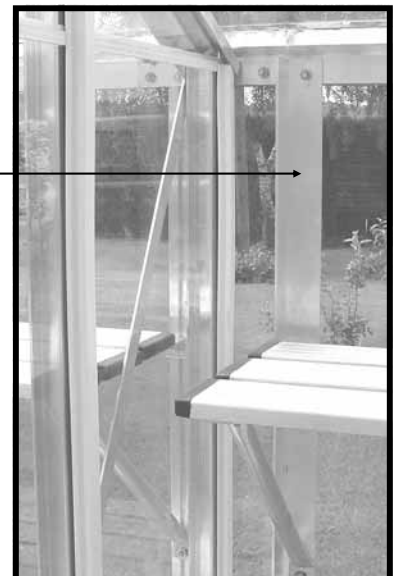

Example: 2x 4' **7** slat staging 'ST0704' = 8' run

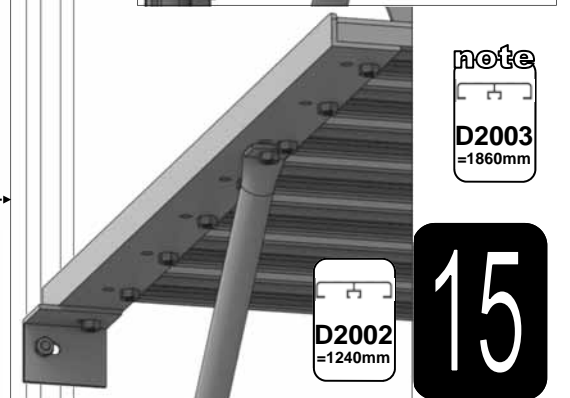
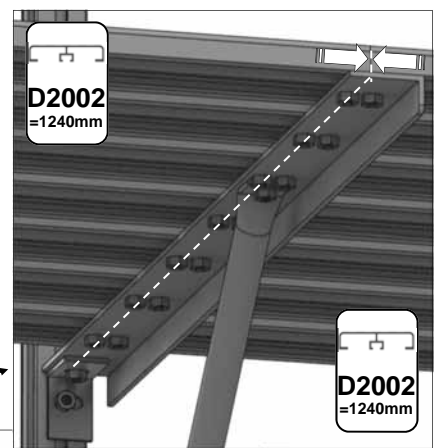
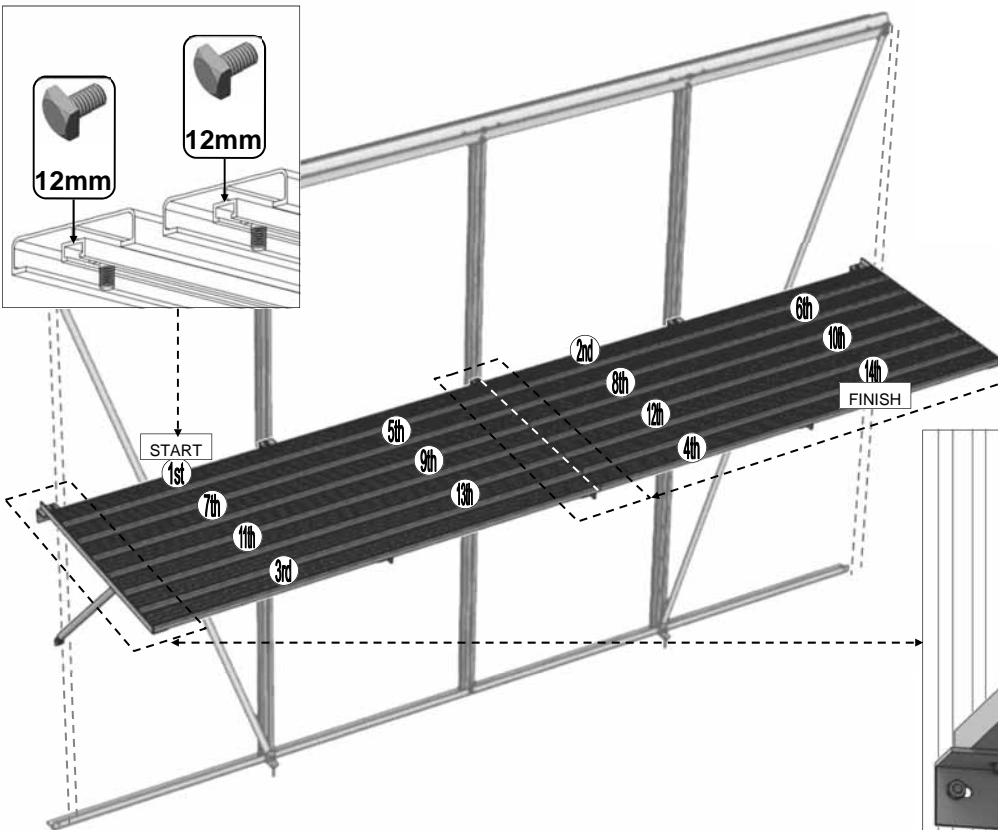
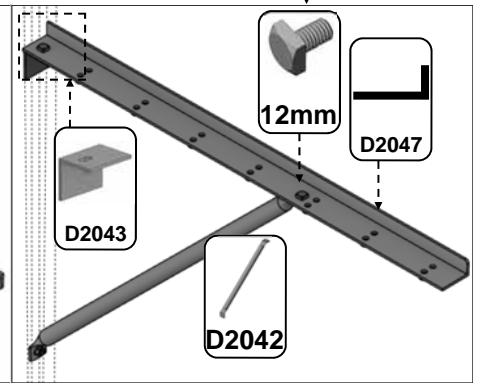
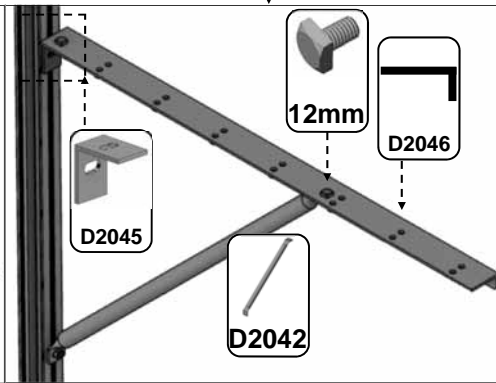
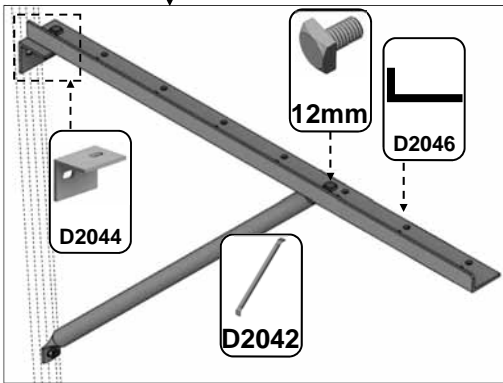
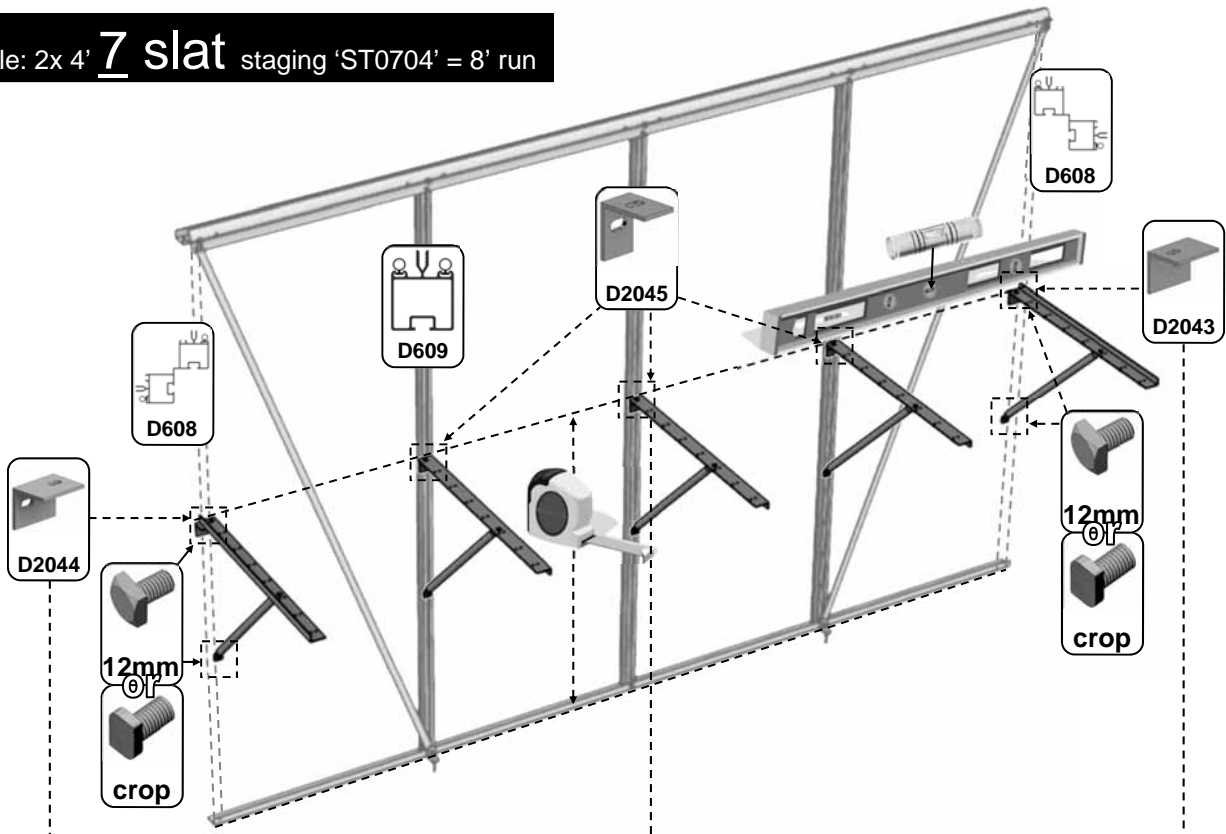

note
D2003 = 1860mm

15

Fixing staging in a dwarf wall model.

To fix the staging diagonal tubular bracings you will have to hammer drill into your brickwork and fix with rawl plugs and screws. You should use a spirit level to make sure each horizontal is accurate and then mark and drill. One of the beauties of Robinsons staging is its adaptability. Because of the rock outcrop on the inside wall of this model the tubular bracings have been attached to the underside of the front staging run with 15mm bolts to give a sharper gradient to the bracings avoiding the rock.

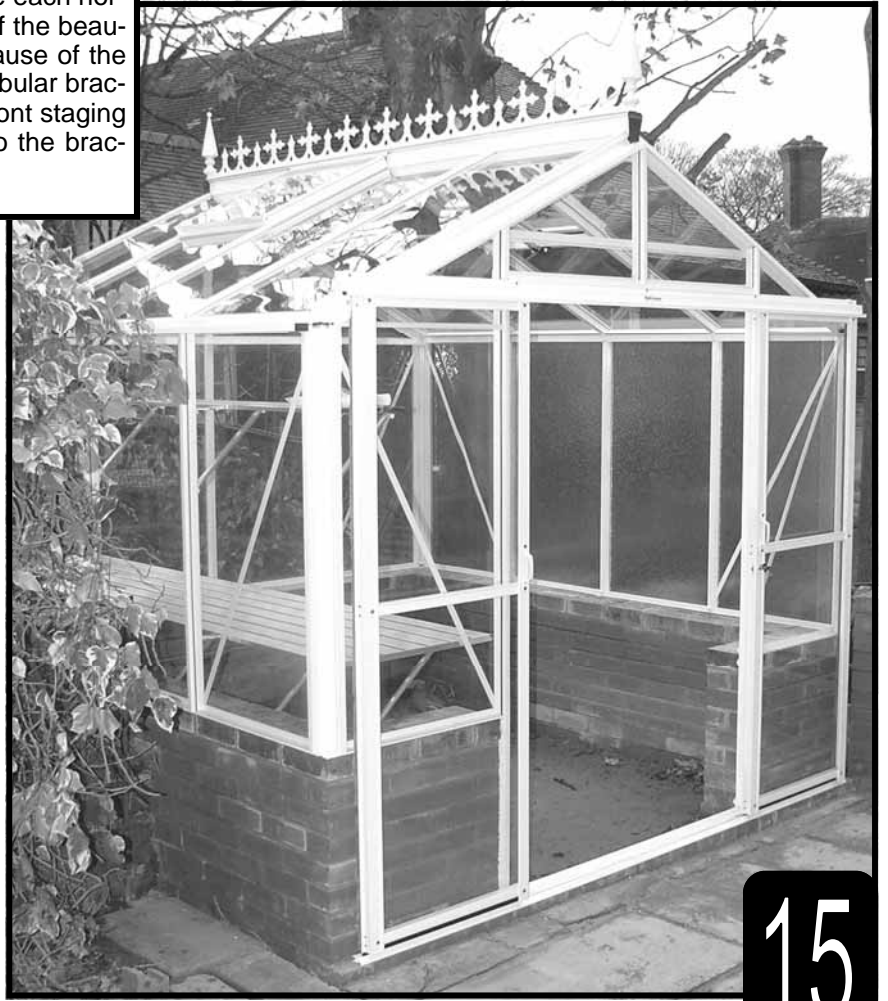

15

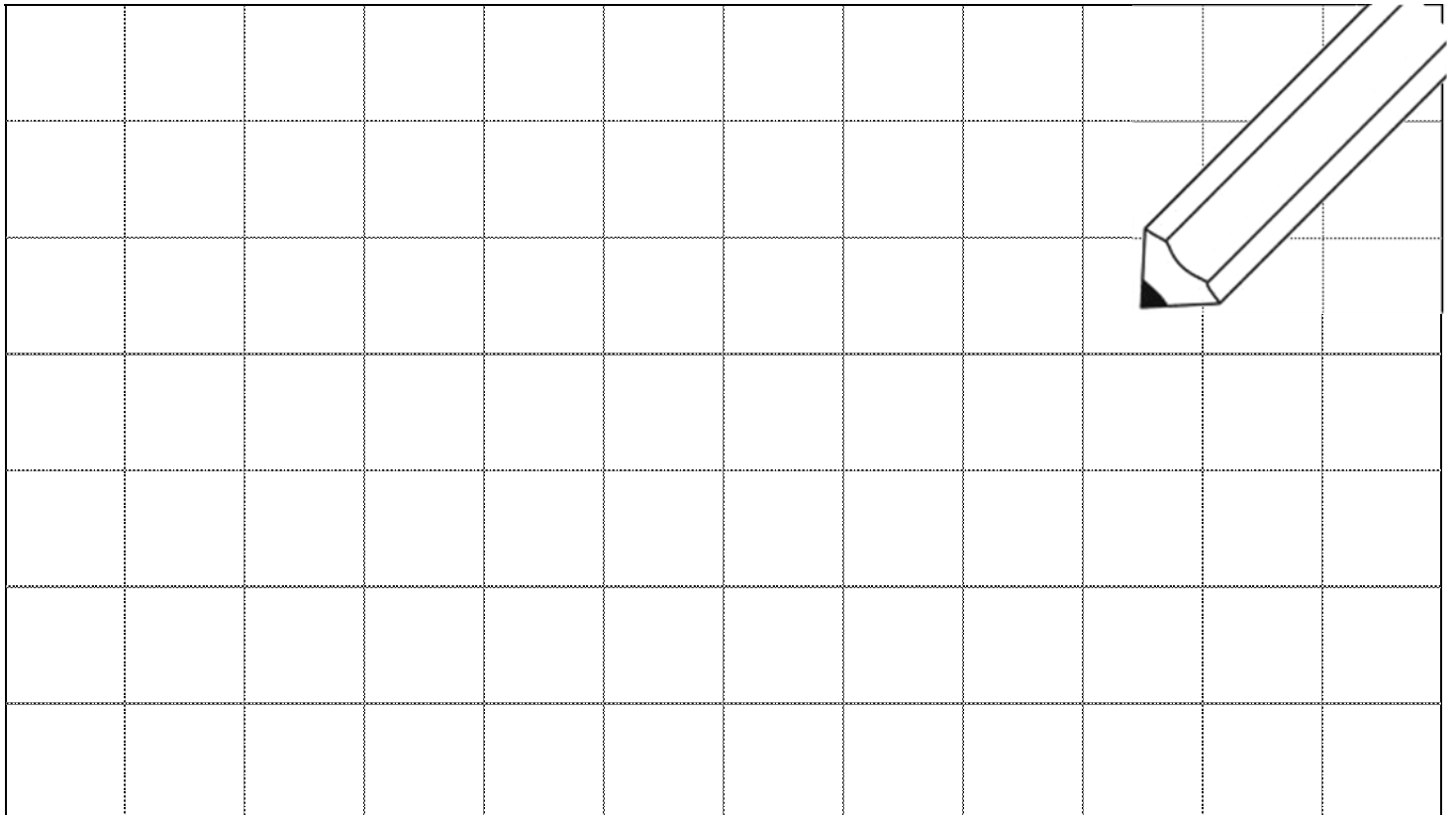

Please be aware that this is a new multi-national manual. If you spot any errors or have any constructive comments regarding the manual please email james.spooner@greenhousepeople.co.uk and I will make the necessary amendments. In addition any photographs of completed buildings would be most appreciated to add to our portfolio.

THIS GREENHOUSE BOX WAS PACKED BY: _____

DATE: _____



www.robinsonsgreenhouses.co.uk

To contact Robinsons Customer Services email us at sales@robinsonsgreenhouses.co.uk or call us on 01782 385 409.

Our address is Robinsons Greenhouses, Unit 19 Blythe Park, Cresswell, Stoke-on-Trent, Staffordshire, ST11 9RD